

Liquid level gauges for steam and process applications



Liquid level gauges

Choosing the right gauge

The determining factor for choosing a gauge is on the one hand the medium, and on the other hand the pressure and temperature range within which the gauge is to be used. It is on these factors that the design, construction materials and finally the price of the gauge depend.

Basically, Klinger liquid level gauges can be used for every medium encountered in practice; our range of construction materials varies from low temperature steels to high-tensile heat-resistant steel.

Level gauges for steam and hot water

Robustly made, safe against glass breakage

Steam boilers are more frequently shut down and started up than other pressure vessels. This puts extreme demands on the glass and the gauge. The glass must withstand the thermal stresses which arise, the gauge body must therefore be stable and rigid. Our gauge bodies are designed to meet the needs of the glass: the glass lies between sealing and cushion gaskets and except for the sight area is completely enclosed by metal. This is one of the prerequisites for the safety of our gauges in service: even if a glass breaks, it remains wedged in the glass housing. Glass splinters cannot be blown out.

Up to 32 bar:

Reflex gauges

On steam boilers where the pressure does not exceed 32 bar, reflex gauges are the best and most economical solution.

Up to 120 bar:

Transparent, mica-protected gauges

Our transparent gauges are offered for the pressure range up to 120 bar. Transparent gauges on steam boilers are provided with an illuminator to ensure perfect visual indication.

Up to 180 bar:

Bi-colour gauges

We have developed bi-colour level gauges for steam pressures up to 180 bar. This insures the clearest indication possible. Such gauges are used exclusively on steam boilers.

Level gauges for media in the processing industry

The service conditions in the process industries (oil refineries, petro-chemical and also chemical plant) are completely different to those in steam generating plant.

Reflex gauges

In the process industry too, the reflex gauge gives the clearest indication regardless of whether the medium is clear or coloured water.

Transparent gauges

If the medium is dirty, viscous or aggressive, flat transparent glasses guarantee better indication since the glass surface can be protected by mica shields against serious attack by the medium.

Temperature range

-196°C to +400°C

Level gauges in the process industries are mainly exposed to nonvarying service conditions: extremely high pressures at low temperatures or low pressure at high temperatures.

Low temperature applications

When working with media under cryogenic conditions it should be ensured that metallic materials display the necessary impact strength. Glass, which is brittle even at room temperature, does not change its properties at low temperatures.

No impairment of vision due to icing

Ice which forms on the gauge glass can make observation difficult. For such cases we offer anti-frost blocks which

ensure complete readability of the level even in low temperature applications.

Gauges fitted with this accessory must of course be well insulated to suit the ambient temperature.

Ancillary heating systems

If the medium tends to become viscous or solidifies when the temperature falls, the deposits formed on the glass can make it impossible to read the level. For such cases we supply ancillary heating systems for the gauge and shut-off fittings. The medium is thereby maintained in the liquid state and good visibility is ensured.

Explosion proof illuminators

With coloured media indication is unexceptionable. If the medium is clear water and a transparent gauge is used, an illuminator must be provided to ensure clear indication of the level. We supply illuminators to class IP 65 E Ex d II cT 6. Type approved according to ATEX.

Liquid level gauges

Operating principle reflex gauges

Reflex gauge

Applications:

Steam: up to 32 bar saturated steam

Indication

Very clear

Steam-Vapour space – silver white

Water-Liquid space – dark

The principle of the reflex glass is based on the difference in the refractive indices of liquid and gas or, in particular, of water and steam. The liquid column is contained within the recess of the centre-piece behind the gauge glass which is clamped within the gauge body.

If a ray of light encounters the surface of one of the 45 °C slanted grooves in the gas or steam space it is reflected to the opposite surface of the groove and from there totally reflected – back into the direction of observation. The steam or gas space therefore appears silver-white.

The gauge glass – a KLINGER reflex glass – has prismatic right angled grooves on the side facing the water and steam spaces. Light rays entering from outside the gauge are either absorbed or reflected depending upon whether they enter the water or steam space.

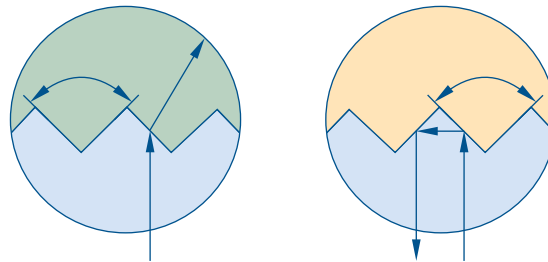

Gauge body

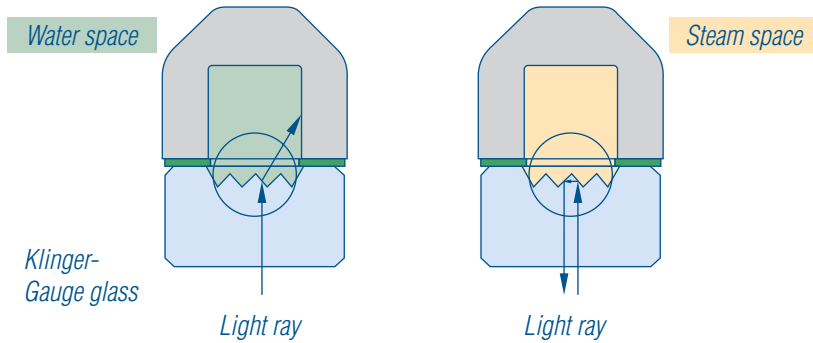

The light ray which encounters the surface of a groove in the liquid space is almost totally absorbed. The liquid behind the reflex glass therefore appears black.

The advantage of the reflex gauge lies in its clear, unambiguous readability. This system makes false readings of the liquid level impossible and thereby eliminates dangers which could arise in this connection.

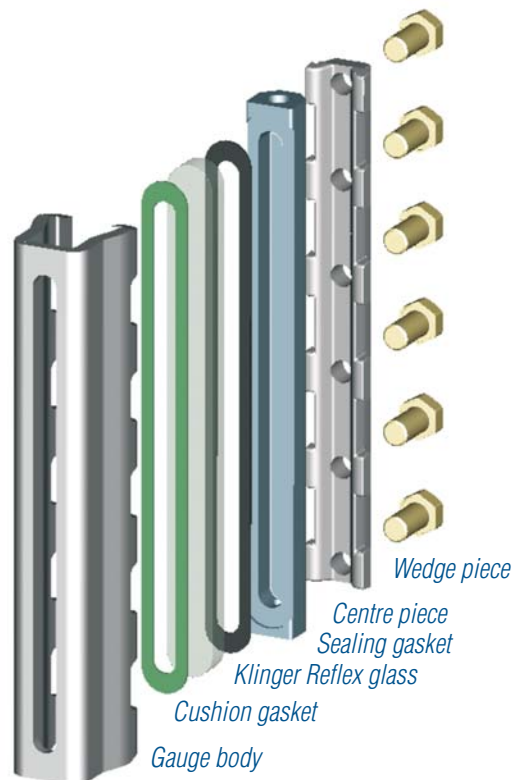
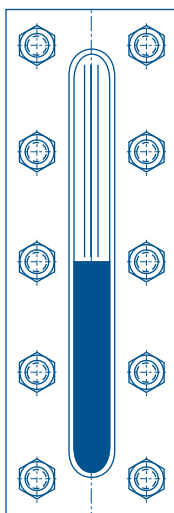



Liquid level gauges

Operating principle transparent gauges

Transparent gauges

Applications:

Steam:

Up to 120 bar saturated steam
The gauge glasses must be protected against the attack of the boiler water by means of mica shields fitted on the side of the glass facing the liquid chamber. An illuminator is invariably required.

Other media:

Up to 340 bar at cold hydraulic pressures (120 °C).
An illuminator is required for water-clear media, with coloured media this may be dispensed with.

Indication:

The indication with coloured liquids appears as a dark column of liquid corresponding to the colour of the medium.

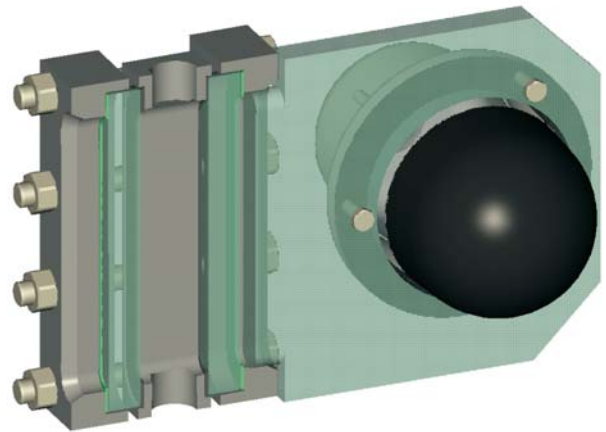

The liquid column is contained between the two gauge-glasses. When necessary an illuminator is mounted on rear-side of the gauge; its light rays are deflected by a louvred screen upwards into the liquid column. Light rays which impinge on the surface of the liquid meniscus are reflected back to the eye of the observer: he sees in the gauge the illuminated surface of the liquid. The clearest indication is attained when the angle between the direction of observation and the liquid surface is approximately the same as that between the light source and the liquid surface. Explosionproof illuminators safety class IP 65, Typ EVA E Ex dII Ct5 Voltage 230 V, 50 Hz. Type approved according to ATEX.

Coloured media are easily observed. With water-clear media or steam, error-free observation is only possible in conjunction with an illuminator. The liquid level is made visible through the reflexion of the light-source in the surface of the liquid. If the observation point is remote from the gauge, the liquid level may also be transmitted via closed-circuit TV to a monitoring console. In this case a TV camera must be directed to the visual surface of the gauge at an angle from below and at a distance of about 2 metres.

Depending on gauge type and design in steam or process applications there are various materials available for sealing gaskets and cushion gaskets.

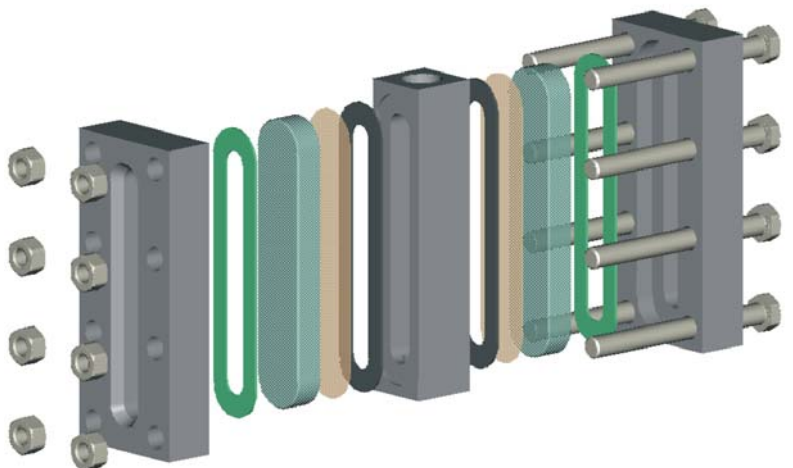

Liquid level gauges

Operating principle bi-colour gauges

Bi-colour gauges

Applications:

For steam services up to 180 bar (+355,5°C); in principle it is a transparent gauge, but with a wedge-shaped centrepiece. For direct observation the gauge is provided with an illuminator containing red and green filters.

Indication:

Water space – green
Steam space – red

Operating principle of bi-colour gauges

The bi-colour level gauge is in principle a transparent gauge in which the centrepiece has a wedge-shaped section. This design makes bi-colour indication possible. Two colour-filters are mounted right in front of the light source of the illuminator – one red and one green. When seen from the front, the red colour filter must always be on the left.

The optical separation of the steam and water spaces is in this case also based on the differential refraction of light in steam and water.

The bi-colour indication utilises the different light breaking coefficients of steam and water: If the red light ray enters the water it is deflected sideways and absorbed. If it enters the steam space it passes through unhindered and appears in the indication as red. Light rays which pass through the green filter are absorbed in the steam space but pass unhindered through the water space: the liquid column is therefore indicated as green. Bi-colour level gauges were developed specially for high-pressure steam boilers and condensate accumulators.

Bi-colour gauges are not installed with on inclination. If the gauge is mounted in an elevated position the liquid level may be reflected down to the observation platform by means of a system of mirrors (max. sight length approx. 780 mm).

For illuminators, class IP65 EEx d II Ct6, we use 15W-bulbs. Type approved according to ATEX.

Red/green indication can of course be transmitted by TV to a distant observation stand.

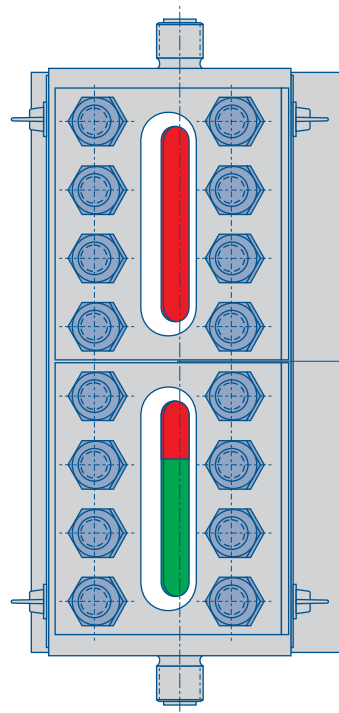

Direct observation
red/green

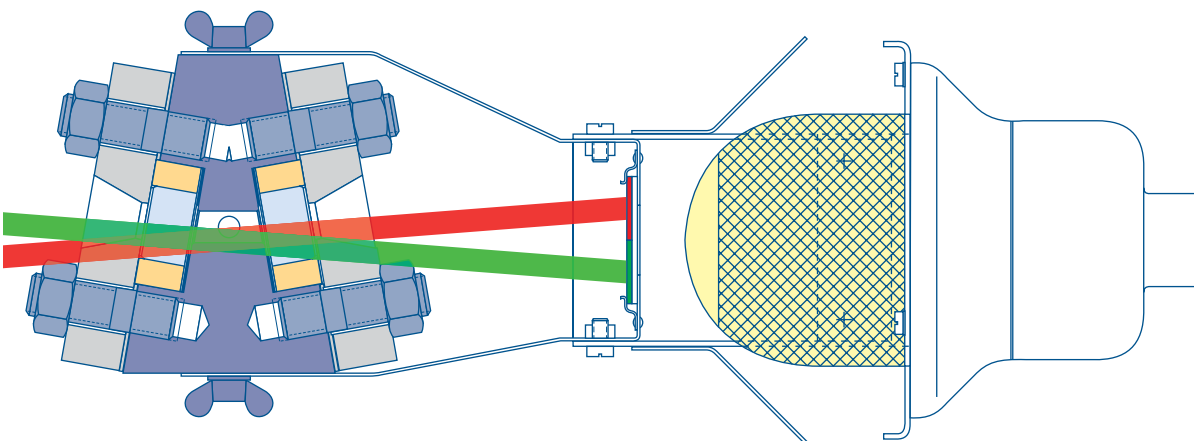



Liquid level gauges

Gauge glasses

Gauge glasses

Liquid level gauges

The gauge glass is the most important component of the liquid level gauge.

KLINGER gauge glasses are suitable for installation in liquid level gauges of almost any make.

We manufacture our gauge glasses ourselves and use exclusively "extra-hard" borosilicate glass which is subsequently heat-treated.

KLINGER gauge glasses have high mechanical strength and are exceptionally resistant to alkalis, acids and boiler water (within the service limitation). Our glass testing laboratory carries out continuously quality control tests: purity of glass, flaws in glass, dimensional accuracy, etc.

This ensures the high quality standard of KLINGER gauge glasses. We manufacture reflex and transparent glasses according to the most varied international standards.

Reflex glasses

The side facing the medium chamber is provided with moulded grooves set at 90° angles. The moulding process increases the resistance of the glass grooves to wear; the "skin" which the glass attains during moulding gives it maximum smoothness and hardness. This makes it extremely resistant to the attack of boiler water.

Applications:

Up to 35 bar saturated steam, reflex glasses provide the optimum solution: they are corrosion resistant and provide an absolutely clear indication. Reflex glasses can be used with all media except steam at service conditions up to 400 bar or temperatures up to 400 °C.



KLINGER transparent glass (above) and reflex glass (underneath)

Transparent glasses

KLINGER transparent glasses are also manufactured from "extra-hard" borosilicate glass. The surfaces on both sides are finely ground and polished to ensure optimal transparency.

Applications:

In steam service above 35 bar and with media with a high pH-value. KLINGER transparent glasses must be protected by a mica shield on the side facing the medium chamber. Transparent glasses should always be chosen for contaminated, viscous or corrosive media. Within the given service limitations they may be used for all media except steam at pressures up to 340 bar or temperatures up to 400 °C.

Packing

KLINGER gauge glasses are packed in individual cardboard boxes. In addition to the glass, each package contains a KLINGER sealing gasket and cushion gasket and forms a complete unit ready for installation.

Note

Only KLINGER original parts guarantee a trouble free operation of the gauge

glasses. Therefore it is recommended to use only original spare parts for gauge glasses, mica shields, sealing gaskets and cushion gaskets.

Standards

We manufacture reflex and transparent glasses in series to the following standards:

OeNORM M 7354 (long gauge glasses)
DIN 7081 (long gauge plate glasses)
JIS B 8211 (Japanese Industrial Standard)
OMV-Spez. H 2009 (OMV-AG, Vienna)
MIL-G-16356 D (US-Navy-Ships)
Esso Eng. Spec. 123 (Esso Research & Engineering Co. – New Jersey)
S.O.D. Spec. 123 (Standard Oil Development Company – New Jersey)
BS 3463 (British Standard Institution).

Quality control

KLINGER reflex and transparent glasses are subject to continuous control during manufacture in order to guarantee exact dimensions, stress conditions, material composition and resistance to bending strain.

Liquid level gauges

Gauge glasses

Quality components

The quality of gauge glass depends on it's:

• chemical composition

The chemical composition as well as the coefficient of expansion is continuously checked through glass analyses.

• mechanical strength

Optimum mechanical strength of a gauge glass is attained through heat treatment (pre-stressing) in which – as in the hardening of steel – the glass is brought to a high temperature and quickly cooled down in a stream of air. This procedure increases the bending and shock resistance of the gauge glass to the value demanded by standards. The thermal pre-stressing of a gauge glass can be checked by means of a polarizing filter: as may be seen in the pictures on page 2 and 3, the stress lines are visible on the outer walls of the gauge glass as interference colours. A non-pre-stressed glass does not display these stress lines.

• dimensional accuracy

We check the dimensional accuracy of every glass using special instruments.

Mica protection

The mica shield must be supported by a glass with a perfectly flat surface. Therefore only transparent (plate) glasses can be mica-protected; this is not possible for glasses provided with reflex grooves.

As already mentioned, gauge glasses must be mica protected on the side facing the medium when used with steam at pressures over 35 bar or with media which cause rapid wear of glass.

Mica is a naturally-occurring substance. Only high-quality mica offers the desired gauge glass protection. Purity-wise our micas meet the requirements of ISO 2185: "stained first quality" up to 70 bar and "stained A quality" above 70 bar. Minimum light transmittancy is 1200 lux and it guarantees optimum readability of the liquid level. KLINGER mica shields are

individually packed to protect them against scratching. An exact, multi-language installation and maintenance leaflet is contained in each package.

Problems of glass wear

Gauge glasses in liquid level gauges on steam boilers are exposed to very high mechanical and chemical stresses. The interface between steam and water is continuously in motion: water evaporates, condensate forms.

Above all, the condensate running down the gauge glasses leaves traces of abrasion.

Boiler water is always chemically treated water from which mineral substances have been extracted. The demineralised water tends, however, to increase its mineral content and extracts this from glass.

This chemical attack on the glass is largely determined by pressure, temperature and pH-value of the boiler water.

With unprotected gauge glasses, steam pressures should not exceed 35 bar nor should it exceed the pH-value of 10, if an economic service life is required. This limiting pH-value applies for feedwater at about 20. °C. It should be noted that the pH-value decreases with increasing



Klinger transparent glass (left side) and reflex glass (right) in polarized light

temperature – 1.5 pH degrees at a temperature rise up to 300 °C.

Areas of application:

- Observation of processes in industrial ovens, driers, filters, strainers, agitators and mixers.
- Observation of vessels such as tanks, boilers, silos
- Supervision of transportation of materials, e.g. in the solid state or liquids such as condensate or cooling fluids.
- Indication of liquid level e.g. of oil level in large gear boxes or of the medium level in impregnation or pouring plants, high capacity transformers, washing plants



Klinger package units for gauge glasses, sealing gasket and cushion gasket



Liquid level gauges

Materials of construction

Material code *)

Code-letters	Parts in contact with medium	Cock plug	Valve internals	Remarks
FS/H	Carbon steel C22.8 **)	Stainless, acid-resistant steel 1.4401-AISI 316	Stainless, acid-resistant steel 1.4401-AISI 316	Carbon steel without copper alloy parts
M/H	Stainless, acid-resistant steel 1.4401-AISI 316 **)	Stainless, acid-resistant steel 1.4401-AISI 316	Stainless, acid-resistant steel 1.4401-AISI 316	Suitable for corrosive media, without copper alloy parts; parts not in contact with medium are made out of carbon steel
M	Stainless, acid-resistant steel 1.4401-AISI 316 **)	Stainless, acid-resistant steel 1.4401-AISI 316	Stainless, acid-resistant steel 1.4401-AISI 316	Specially suitable for corrosive media, may also be used at low temperatures; all parts ***) are made out of stainless, acid-resistant steel

*) Other materials on request

**) For exakt details see relevant pages >>Part lists and materials<<

***) Operating parts excepted

Comparison of the most important material designations

Material designation acc. to Klinger-catalogue	Material class	DIN designation	Material no. to VDEh or DIN	AISI designation	BS designation	ASTM designation
C 22.8	Forged steel	C 22.8	1.0460	M 1020	1503-161 Gr. B	A 181 Gr. II
Ck 35	Forged steel	Ck 35	1.1181	M 1035	-	-
Ck 45 N	Forged steel	Ck 45 N	1.1191	-	-	-
St 35	Structural steel	St 35	1.0308	M 1010	-	-
St 42.2	Structural steel	St 42.2	1.0181	-	-	A 105-65 Gr. I
St 60	Structural steel	St 60	1.0543	M 1044	-	-
1.4301	Stainless steel	X5CrNi189	1.4301	304	304-S15	A 182-F 304
1.4305	Acid-resistant steel *)	X12CrNiS188	1.4305	303	303-S21	A 194 Gr. 8 F
1.4523	Stainless steel	X8CrMoTi17	1.4523	-	-	-
1.4401	Acid-resistant steel	X5CrNiMo1810	1.4401	316	316-S16	A 182-F 316

*) Or low-temperature resistant steel

Liquid level gauges

Summary of types

Primarily application in power generating plants (steam)

	Gauge body with shut-off fitting	Material code no.	Service limitation		Pressure rating PN
			bar	°C	
Reflex gauges	R 100-D	FS/H, M/H	22	216	40
	K-D	FS/H	32	236	40 ¹⁾
Transparent gauges	T85-DA	FS/H	85	298	160
	T85-DVK 2	FS/H	85	298	160
	TA 120-DVK 2	FS/H	120	323	250
Bi-colour gauges	KTA-DVK 2	FS/H	120	323	250
			180	356	315

¹⁾ In special pattern (with coupled end tubes) may be used up to a max. of PN 100/120 °C

Primarily to process applications

	Gauge body with shut-off fitting	Material code no.	Service limitation		Pressure rating		Medium
			bar	°C	ANSI	PN	
Reflex gauges	R 25-DG/RAV		on request				All media except steam
	R 100-DG/RAV	FS/H, M/H	100	120	600	100	
			62	400			
	R 100-DG/RAV	M	63	120	400	63	
			37	400			
	R 160-DG/RAV	FS/H, M/H	160	120	900	160	
			97	400			
	R 160-DG/RAV	M	99	120	600	100	
			58	400			
	A 400	on request	400	120	2500	400	
	R 250-RAV	on request					
	UOR-DG/RAV	FS/H	63	120	400	63	Low boiling point media
		47	400				
UOR-RAV	M/H	38	120	300	40		
Transparent gauges			28	400			All media except steam
	T 50-DG/RAV	FS/H, M/H	68	120	300	40	
			47	400			
	T 50-DG/RAV	M	25	120	(150)	25	
			18	400			
	T 100-DG/RAV	FS/H, M/H	100	120	600	100	
			62	400			
	T 100-DG/RAV	M	63	120	400	63	
			37	400			
	T 160-DG/RAV	FS/H, M/H	160	120	900	160	
			97	400			
	T 250-RAV	on request					Low boiling point media
UOT-DG/RAV	FS/H	63	120	400	63		
		47	400				
			38	120	300	40	
			28	400			

For all gauges used at working temperatures above 300 °C (with A 4 screws) service conditions are given by material code M.

Note: The body bolt torques shown on the individual pages are reduced by 30% for A 2 or A 4 bolts.



Liquid level gauges

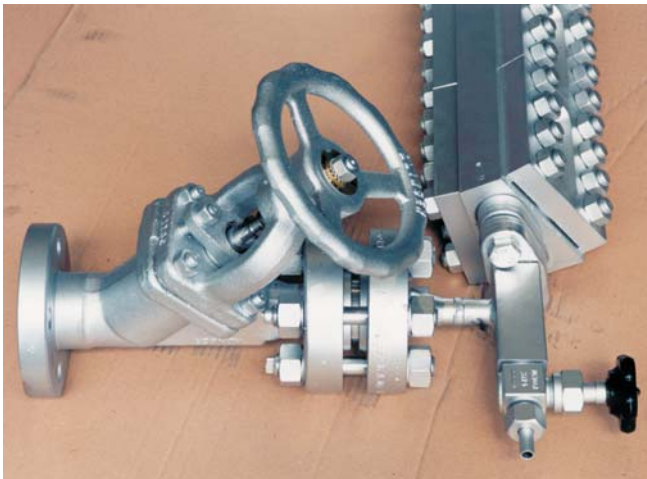
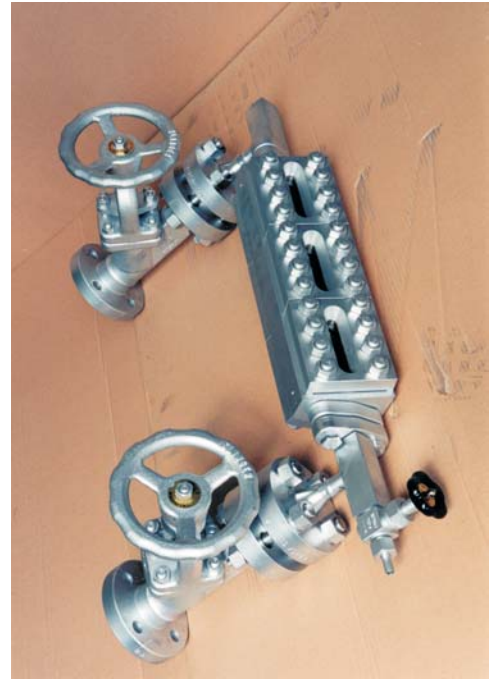
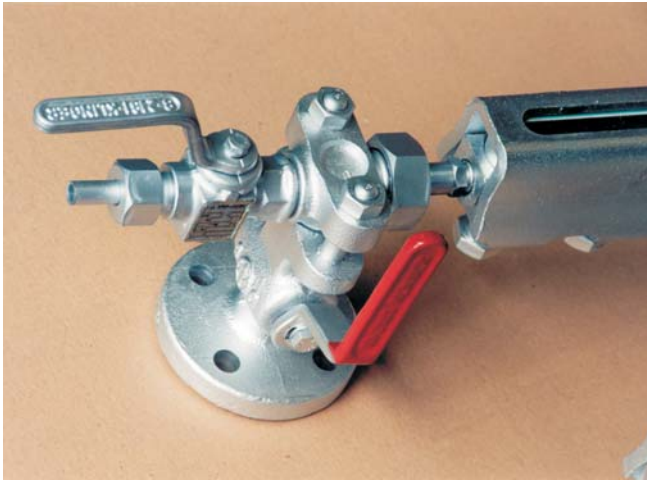

References

- | | |
|----------------|---------------|
| ■ ABB | ■ Lenzing |
| ■ Bayer | ■ Lurgi |
| ■ BP | ■ Mobil |
| ■ Ciba | ■ MOL |
| ■ Dow Chemical | ■ Neste OY |
| ■ ESSO | ■ Norsk Nydro |
| ■ FW Vienna | ■ OMV |
| ■ Hoechst | ■ Sasol |
| ■ JGC | ■ Shell |
| ■ Koszience | ■ Sloznaft |
| ■ Kvaerner | ■ Solvay |

Liquid level gauges

Steam application

Part lists and materials

R 100-D

Pos.	Part	Materials	
		FS/H	M/H
1	Level gauge body	A 105	A 316
2	Cover	A 105	A 105
5	Glass	Borosilicate	Borosilicate
6	Sealing gasket	Graphite	Graphite
7	Cushion joint	Klinger-SIL	Klinger-SIL
8	Bolt	B7	B7
9	Nut	2H	2H

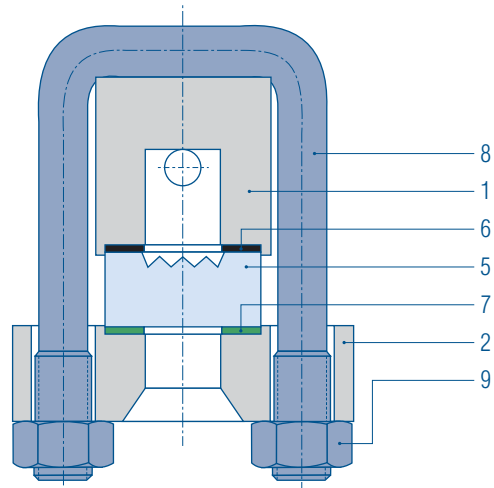

K

Pos.	Part	Materials
		FS/H
1	Gauge cover	Ck 35
2	Centre piece	C22.8
3	Wedge piece	C22.8
6	Reflex glass	Borosilicate glass
7	Cushion joint	K-Sil
8	Sealing joint	Graphite
10	Hexagon-headed screw	5.6

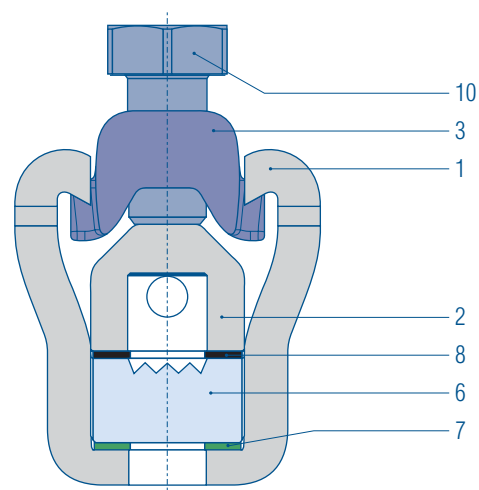



Liquid level gauges

Steam application

T 85

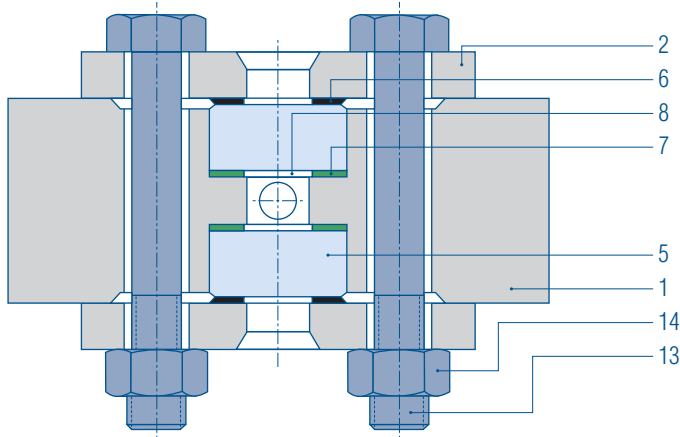

Part lists and materials

Pos.	Part	Materials
		FS/H
1	Level gauge body	A 105
2	Cover	A 105
5	Glass	Borosilicate
6	Cushion joint	Klinger-SIL
7	Sealing gasket	Graphite
8	Mica shield	Stained first quality
13	Screw	B7
14	Nut	2H

TA 120

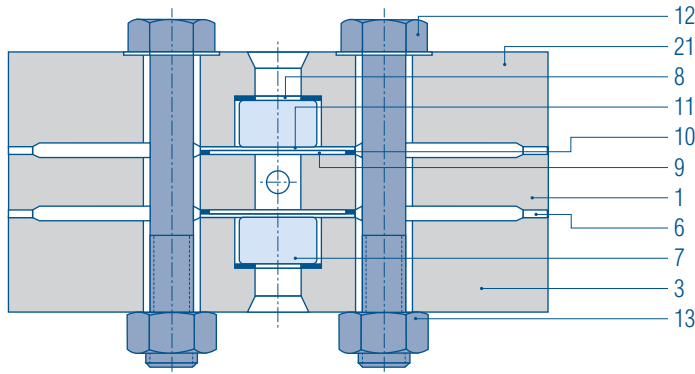

Pos.	Part	Materials
		FS/H
1	Level gauge body	A 105
2/3	Cover	A 105
6	Spacer strip	Ms 60 F 48
7	Glass	Borosilicate
8	Cushion joint	Klinger-SIL
9	Sealing gasket	Graphite
10	Mica shield	Stained first quality
11	Protective joint	Graphite
12	Screw	8.8
13	Nut	2H

KTA

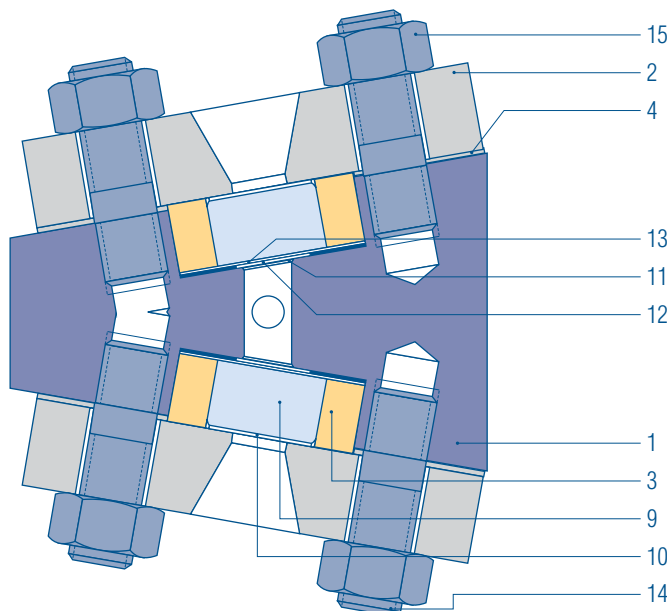

Pos.	Part	Materials
		FS/H
1	Centre piece	Ck 45 N
2	Cover plate	Ck 45 N
3	Glass holder	1.0570
4	Spacer strip	1.4401
8	Glass protector	Mica ¹⁾
9	Transparent glass	Borosilicate glass
10	Cushion joint	Graphite
11	Sealing joint	Graphite
12	Mica shield	stained A quality
13	Protective gasket	Graphite
14	Stud bolt	1.7709
15	Hexagon nut	1.7258

¹⁾ not shown on drawing

Reflex level gauges

Steam application

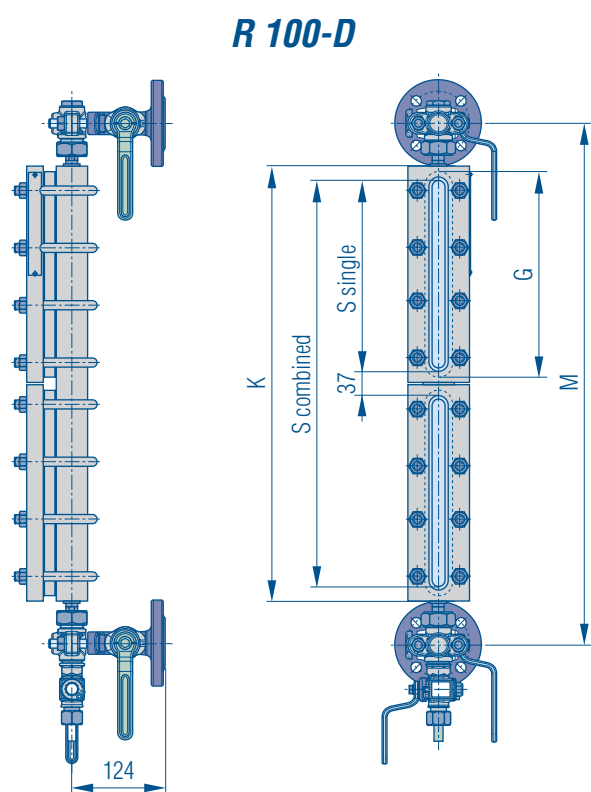

R 100-D

Nominal pressure: PN 40, 22 bar
216 °C saturated steam
with gauge cock D
Construction to KLINGER
material code FS/H, M/H
Gauge glass:
Klinger Reflex glass B
Material Borosilicate

R 100-D
PN 40
22 bar
216 °C
saturated steam

Connection
gauge body – gauge cock

Rotatable (360°)
 End tubes o.D. 16 mm
 The seal is made by a stuffing box in the gauge cock and a joint ring on the gauge.

Connection construction

End connection with D gauge cocks (see illustration). Safety ball in the upper and lower shut-off fitting.

Vessel connection by flange or male thread available to all recognized standards.

Weight: Gauges cocks with DN 25 flanges approx. 7,3 kg.

Torque for gauge bolts 50 Nm, cold.

For gauge body and gauge cock part lists, dimensions of glasses and material specifications see pages 11 and 36.

Suggested order specification
Reflex level gauge PN 40

KLINGER material code FS/H, M/H
 Gauge glass Borosilicate thermally prestressed
 Connection gauge body – gauge cock rotatable
 Shut-off fittings gauge cocks
 With safety balls

Ordering example:
R 100-D, IX, FS/H
DN 25 / PN 40
M= 460 mm

Overall and connection dimensions (mm)

Gauge size	Centre-to-centre distance M min	Body length K	Sight length S	Glass length G	Approx. weight of gauge (kg)
II	255	153	118	140	3,40
III	280	178	143	165	3,70
IV	305	203	168	190	4,10
V	335	233	198	220	4,80
VI	365	263	228	250	5,40
VII	395	293	258	280	5,90
VIII	435	333	298	320	6,80
IX	455	353	318	340	7,10
2 x IV	510	408	373	190	8,40
2 x V	570	468	433	220	9,90
2 x VI	630	528	493	250	11,00
2 x VII	690	588	553	280	12,10
2 x VIII	770	668	633	320	13,80
2 x IX	810	708	673	340	14,50
3 x VI	895	793	758	250	16,50
3 x VII	985	883	848	280	18,10
3 x VIII	1105	1003	968	320	20,70
3 x IX	1165	1063	1028	340	21,80
4 x VII	1280	1178	1143	280	24,20
4 x VIII	1440	1338	1303	320	27,70
4 x IX	1520	1418	1383	340	29,10
5 x VII	1575	1473	1438	280	30,20
5 x VIII	1775	1673	1638	320	34,60
5 x IX	1875	1773	1738	340	36,30
6 x VIII	2110	2008	1973	320	41,50
6 x IX	2230	2128	2093	340	43,60
7 x VIII	2445	2343	2308	320	48,40
7 x IX	2585	2483	2448	340	50,90



Reflex level gauges

Steam application

K Nominal pressure: PN 40, 32 bar
 236 °C saturated steam
 PN 40 with gauge cock D
 32 bar Construction to KLINGER
 236 °C material code FS/H
 saturated steam Gauge glass:
 Klinger Reflex glass A
 Material Borosilicate

Connection gauge body – gauge cock

Rotatable (360°)
 End tubes o.D. 16 mm
 The seal is made by a stuffing box in
 the gauge cock and a joint ring on the
 gauge.

Connection construction

End connection with D gauge cocks
 (see illustration). Safety ball in the
 upper and lower shut-off fitting.

Vessel connection by flange or male
 thread available to all recognized
 standards.

Weight: Gauges cocks with DN 20
 flanges approx. 7,3 kg.

**Torque for gauge bolts 60 Nm,
 cold.**

For gauge body and gauge cock part
 lists, dimensions of glasses and
 material specifications see pages 11
 and 36.

Suggested order specification Reflex level gauge PN 40

KLINGER material code FS/H

Gauge glass Borosilicate
 thermally prestressed

Connection gauge body – gauge cock
 rotatable

Shut-off fittings gauge cocks

With safety balls

Ordering example:

K-D, 2 x VI, FS/H

DN 20 / PN 40

M= 615 mm

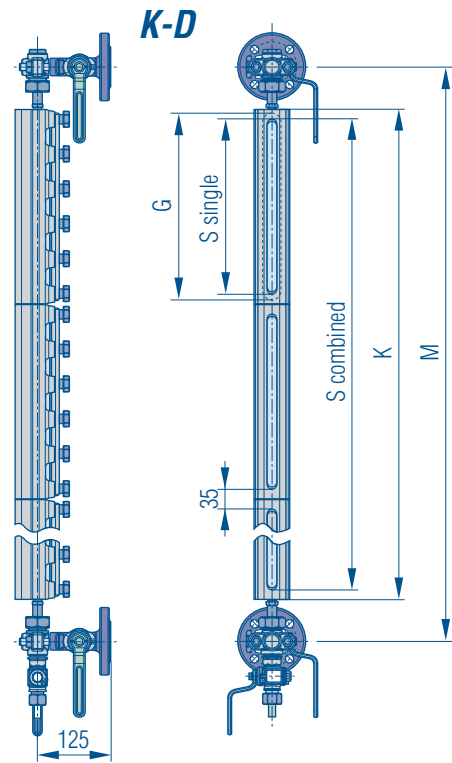

Overall and connection dimensions (mm)

Gauge size	Centre-to-centre distance M min	Body length K	Sight length S	Glass length G	Approx. weight of gauge (kg)
III	265	177	143	165	4,30
IV	290	202	168	190	5,00
V	320	232	198	220	5,50
VI	350	262	228	250	6,70
VII	380	292	258	280	6,90
VIII	420	332	298	320	7,80
IX	440	352	318	340	8,50
2 x IV	495	406	373	190	10,00
2 x V	555	466	433	220	11,00
2 x VI	615	526	493	250	13,40
2 x VII	675	586	553	280	13,80
2 x VIII	755	666	633	320	15,60
2 x IX	795	706	673	340	17,00
3 x VI	880	790	758	250	20,10
3 x VII	970	880	848	280	20,70
3 x VIII	1090	1000	968	320	23,40
3 x IX	1150	1060	1028	340	25,50
4 x VII	1265	1174	1143	280	27,60
4 x VIII	1425	1334	1303	320	31,20
4 x IX	1505	1414	1383	340	34,00
5 x VII	1560	1468	1438	280	34,50
6 x VI	1675	1582	1553	250	40,20
5 x VIII	1760	1668	1638	320	39,00
5 x IX	1860	1768	1738	340	42,50
7 x VI	1940	1846	1818	250	46,90
6 x VIII	2095	2002	1973	320	46,80
6 x IX	2215	2122	2093	340	51,00
7 x VIII	2430	2336	2308	320	54,60
7 x IX	2570	2476	2448	340	59,50

The maximum centre-to-centre distance $M_{max} = M_{min} + 129$

Transparent level gauges

Steam application

T 85-DA

T 85-DVK 2

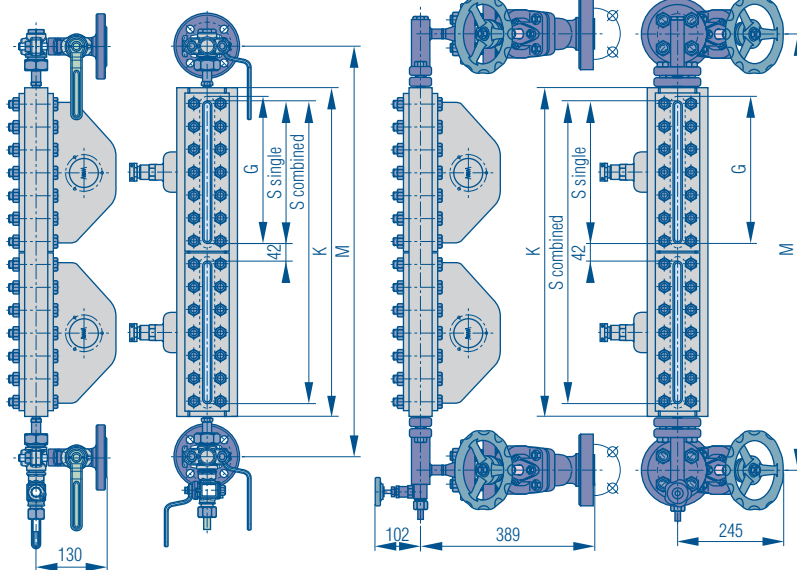

Nominal pressure: PN 160, 85 bar
298 °C saturated steam
with gauge cock DA
with gauge valve DVK 2
Construction to KLINGER
material code FS/H
Gauge glass:
Klinger Transparent glass B
Material Borosilicate
Mica shield B
Illuminator IP 65

T 85
PN 160
85 bar
298 °C
saturated steam

Connection
gauge body – gauge cock

Rotatable (360°)
Gauge cock DA: Connecting piece and connecting nut. Seal between gauge and connecting piece joint ring.
Gauge valve DVK 2: Connecting piece with flanges. Seal between gauge and connecting piece joint ring

Connection construction

End connection with gauge cocks DA and gauge valves DVK 2 (see illustration). Safety ball in the upper and lower shut-off fitting.

Vessel connection with flanges or male threads to all recognized standards.

Weight: Gauges cocks with DN 25 flanges approx. 9,5 kg.

Gauge valve set approx. 44 kg.

Torque for body bolts 100 Nm, cold 92 Nm under working conditions.

For gauge body and gauge cock part lists, dimensions of glasses and material specifications see pages 12 and 39.

Suggested order specification

Transparent level gauge PN 160

KLINGER material code FS/H

Gauge glass Borosilicate

thermally prestressed

Connection gauge body – shut-off fitting

rotatable

Shut-off fittings gauge cocks and gauge valves

with safety balls

Ordering example:

T 85-DVK 2, 4 x IX, FS/H
DN 25 / PN 160

Overall and connection dimensions (mm)

Gauge size	Centre-to-centre distance M min	Body length K	Sight length S	Glass length G	Approx. weight of gauge (kg)
II	313	180	115	140	16,10
III	338	205	140	165	17,50
IV	363	230	165	190	18,60
V	393	260	195	220	20,30
VI	423	290	225	250	22,20
VII	453	320	255	280	23,50
VIII	493	360	295	320	26,10
IX	513	380	315	340	27,70
2 x IV	570	437	372	190	24,70
2 x V	630	497	432	220	27,40
2 x VI	690	557	492	250	32,00
2 x VII	750	617	552	280	35,70
2 x VIII	830	697	632	320	40,60
2 x IX	870	737	672	340	43,10
3 x VI	957	824	759	250	48,10
3 x VII	1047	914	849	280	53,60
3 x VIII	1167	1034	969	320	60,60
3 x IX	1227	1094	1029	340	64,70
4 x VII	1344	1211	1146	280	71,50
4 x VIII	1504	1371	1306	320	81,30
4 x IX	1584	1451	1386	340	86,30
5 x VII	1641	1508	1443	280	89,40
5 x VIII	1841	1708	1643	320	101,70
5 x IX	1941	1808	1743	340	107,80
6 x VIII	2178	2045	1980	320	122,10
6 x IX	2298	2165	2100	340	129,40
7 x VIII	2515	2382	2317	320	142,50
7 x IX	2655	2522	2457	340	151,00
8 x IX	3012	2879	2814	340	172,60

The maximum centre-to-centre distance $M_{max} = M_{min} + 116$



Transparent level gauges

Steam application

TA 120

PN 250

120 bar

**323 °C
saturated steam**

Nominal pressure:

PN 250, 120 bar

323 °C saturated steam

with gauge valve DVK 2

Construction to KLINGER

material code FS/H

Gauge glass:

Klinger Transparent glass TA 28

Material Borosilicate

Mica shield TA 28

Illuminator IP 65

TA 120-DVK 2

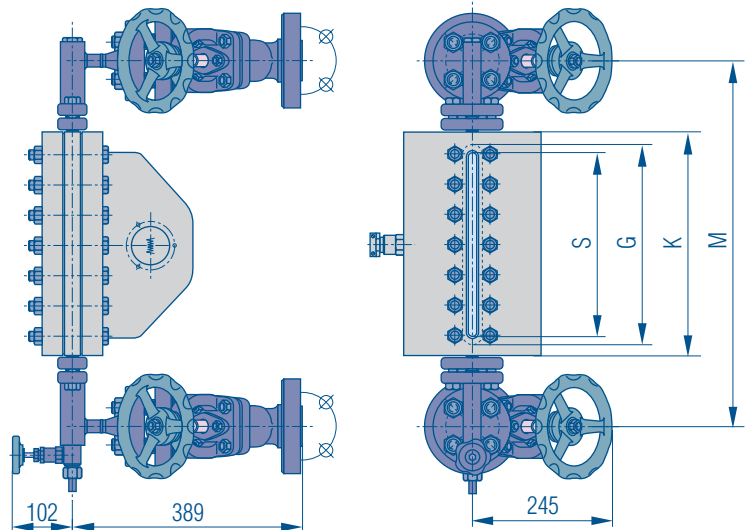

Overall and connection dimensions (mm)

Gauge size	Centre-to-centre distance M min	Body length K	Sight length S	Glass length G	Approx. weight of gauge (kg)
III	353	220	145	163	30,00
IV	378	245	170	188	33,00
V	408	275	200	218	38,00
VI	438	305	230	248	44,00
VII	468	335	260	278	52,00
VIII	508	375	300	318	62,50
IX	528	395	320	338	69,50

The maximum centre-to-centre distance $M_{max}=M_{min}+116$, larger centre-to-centre distances can be achieved by the use of mounting plates.

Connection

gauge body – gauge valve

Rotatable (360°)

Connecting piece with flanges. Seal between gauge and connecting piece: joint ring.

Connection construction

End connection with DVK 2 gauge valves (see illustration). Safety ball in the upper and lower shut-off fitting.

Vessel connection by flanges or male threads available to all recognized standards.

Weight: Gauge valve set with DN 25 flanges approx 44 kg.

Torque for body bolts 300 Nm, cold 270 Nm under working conditions.

For gauge body and gauge valve part lists, dimensions of glasses and material specifications see pages 12 and 39.

Suggested order specification

Transparent level gauge PN 250

KLINGER material code FS/H

Gauge glass Borosilicate

thermally prestressed

Connection gauge body – shut-off

fittings rotatable

Shut-off fittings gauge valves

with safety balls

Ordering example:

TA 120-DVK 2, VIII, FS/H

DN 25 / PN 250

M= 508 mm

High pressure bi-colour gauges

Steam application

KTA-DVK 2

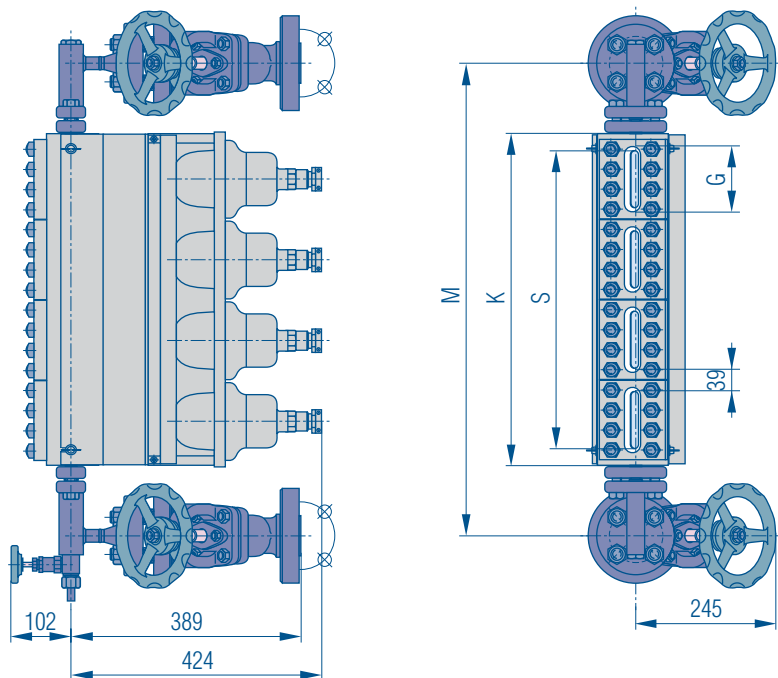

Nominal pressure:
PN 315, 180 bar
355,5 °C saturated steam
with gauge valve DVK 2
Construction to KLINGER
material code FS/H

Gauge glass:
Klinger Transparent glass TA 28
material Borosilicate
Mica shield TA 28
Illuminator IP 65
 with red/green indication
 for direct observation or by mirrors,
 and for TV transmission

KTA
PN 315
180 bar
355,5 °C
saturated steam

Overall and connection dimensions (mm)

Gauge size	Centre-to-centre distance <i>M min</i>	Body length <i>K</i>	Sight length <i>S</i>	Glass length <i>G</i>	Approx. weight of gauge (kg)
2 x I	423	290	233	113	24
3 x I	559	426	369	113	36
4 x I	695	562	505	113	48
5 x I	831	698	641	113	60
6 x I	967	834	777	113	72

The maximum centre-to-centre distance $M_{max}=M_{min}+116$

Connection gauge body – gauge valve

Rotatable (360°)

Connecting piece with flanges. Seal between gauge and connecting piece: joint ring.

Connection construction

End connection with gauge valves DVK 2 (see illustration). Safety ball in the upper and lower shut-off fitting.

Vessel connection with flanges or male thread available to all recognized standards.

Weight: Gauge valve set with DN 25 flanges approx 44 kg.

Torque for gauge bolts 150 Nm, cold 120 Nm under working conditions.

For gauge body and gauge valve part lists, dimensions of glasses and material specifications see pages 12 and 39.

Suggested order specification Bi-colour level gauge PN 315

red/green indication
 KLINGER material code FS/H
 Gauge glass Borosilicate thermally prestressed
 Connection gauge body – shut off fittings rotatable
 Shut-off fittings gauge valves with safety balls

Ordering example:
KTA-DVK 2, 3 x I, FS/H
DN 25 / PN 315
M= 600 mm



Reflex level gauges

Process application

R 25

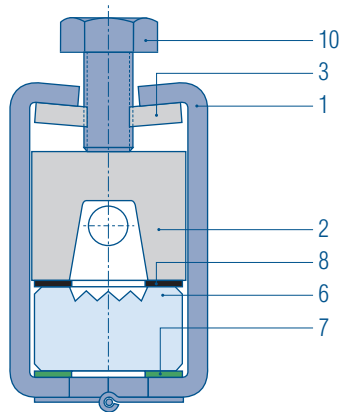

Part lists and materials

Pos.	Part	Materials	
		FS/H	M/H
1	Level gauge body	A 105	A 316
2	Cover	Fe 430	Fe 430
3	Threaded plate	Fe 430	Fe 430
6	Glass	Borosilicate	Borosilicate
7	Cushion joint	Klinger-SIL	Klinger-SIL
8	Sealing gasket	Graphite	Graphite
10	Bolt	8.8	8.8

R 100 / R 160

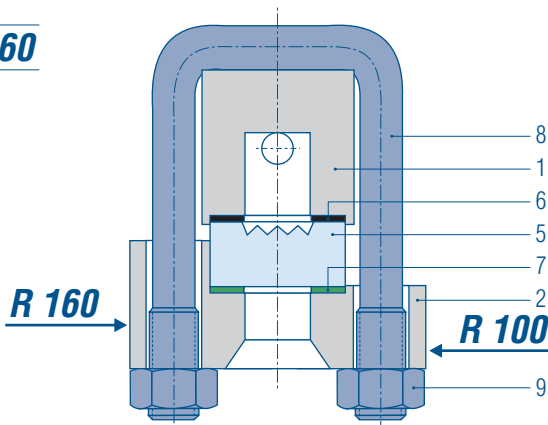

Pos.	Part	Materials	
		FS/H	M/H
1	Level gauge body	A 105	A 316
2	Cover	A 105	A 105
5	Glass	Borosilicate	Borosilicate
6	Sealing gasket	Graphite	Graphite
7	Cushion joint	Klinger-SIL	Klinger-SIL
8	Bolt	B7	B7
9	Nut	2H	2H

R 250

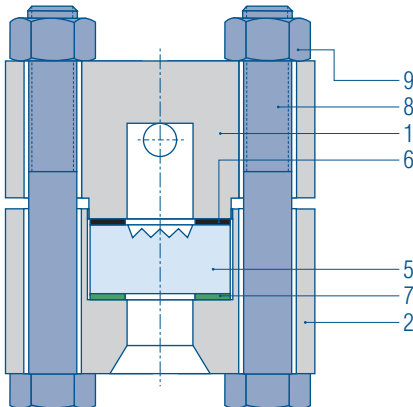

Pos.	Part	Materials	
		FS/H	M/H
1	Level gauge body	A 105	A 316
2	Cover	A 105	A 105
5	Glass	Borosilicate	Borosilicate
6	Sealing gasket	Graphite	Graphite
7	Cushion joint	Klinger-SIL	Klinger-SIL
8	Bolt	B7	B7
9	Nut	2H	2H

UOR

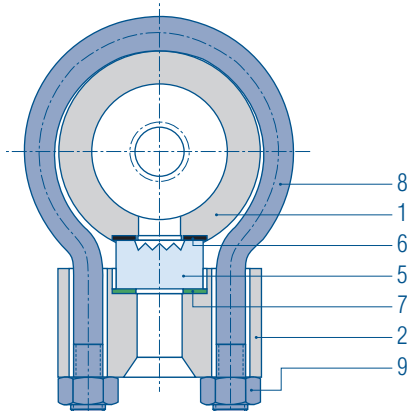

Pos.	Part	Materials	
		FS/H	M/H
1	Level gauge body	A 106 3	A 316
2	Cover	A 105	A 105
5	Glass	Borosilicate	Borosilicate
6	Sealing gasket	Graphite	Graphite
7	Cushion joint	Klinger-SIL	Klinger-SIL
8	Bolt	B7	B7
9	Nut	2H	2H

Liquid level gauges

Process application

Part lists and materials

Pos.	Part	Materials	
		FS/H	M/H
1	Level gauge body	A 105	A 316
2	Cover	A 105	A 105
5	Glass	Borosilicate	Borosilicate
6	Sealing gasket	Graphite	Graphite
7	Cushion joint	Klinger-SIL	Klinger-SIL
8	Bolt	B7	B7
9	Nut	2H	2H

Pos.	Part	Materials	
		FS/H	M/H
1	Level gauge body	A 105	A 316
2	Cover	A 105	A 105
5	Glass	Borosilicate	Borosilicate
6	Sealing gasket	Graphite	Graphite
7	Cushion joint	Klinger-SIL	Klinger-SIL
8	Bolt	8.8	8.8
9	Nut	2H	2H

Pos.	Part	Materials	
		FS/H	M/H
1	Level gauge body	A 105	A 316
2	Cover	A 105	A 105
5	Glass	Borosilicate	Borosilicate
6	Sealing gasket	Graphite	Graphite
7	Cushion joint	Klinger-SIL	Klinger-SIL
8	Bolt	8.8	8.8
9	Nut	2H	2H

Pos.	Part	Materials	
		FS/H	M/H
1	Level gauge body	A 106 B	A 316
2	Cover	A 105	A 105
5	Glass	Borosilicate	Borosilicate
6	Sealing gasket	Graphite	Graphite
7	Cushion joint	Klinger-SIL	Klinger-SIL
8	Bolt	B7	B7
9	Nut	2H	2H

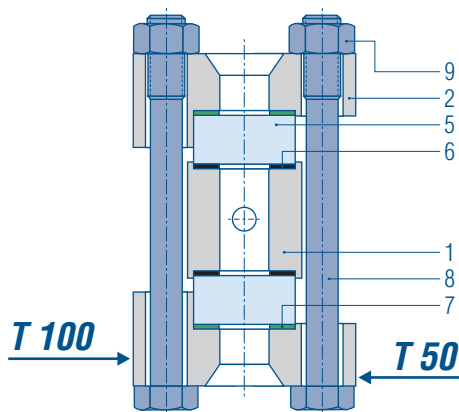

T 50 / T 100

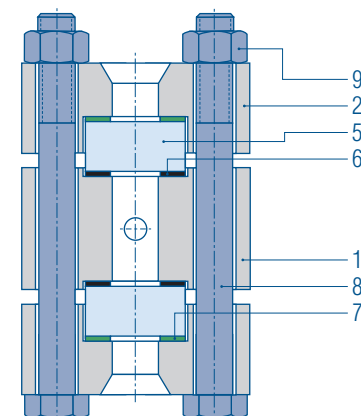

T 160

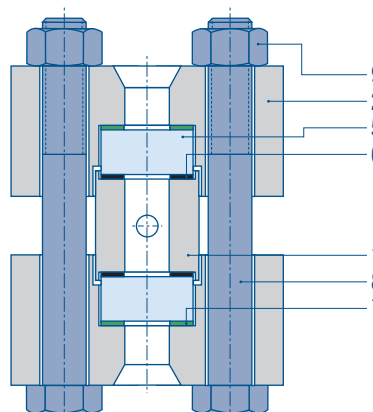

T 250

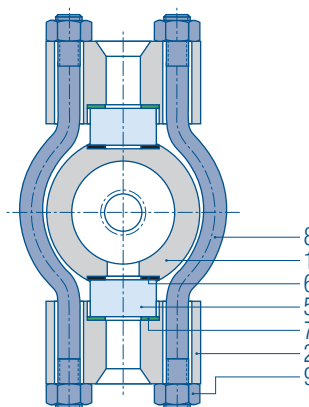

UOT



Reflex level gauges

Process application

R 25* Nom. pressure: PN 25, ANSI 150
 with gauge cock DG
 PN 25 with gauge valve RAV 946, 956,
 ANSI 150 947, 957

*) former type designation LDR

Construction to KLINGER
 material code FS/H, M/H
Gauge glass:
 Klinger Reflex glass A
 Material Borosilicate

Connection gauge body – gauge valve

Not rotatable: 1/2"-NPT double nipple gauge cock DG, gauge valve RAV 946, 956

Rotatable: Union nut and nipple 1/2"-NPT, gauge valve RAV 947, 957
 Seal between nipple and gauge valve: joint ring.

Connection construction

End connection with gauge cock DG or gauge valve RAV 946 (see illustration) and RAV 947 with handwheel or weighted lever (page 40). Safety ball in the upper and lower shut-off fitting.

Gauges without gauge valves:

End, side or back connections with flanges or female thread.

Vessel connection with flanges or male thread to all recognized standards.

Weight: Gauges cock set with DN 25 flanges approx. 7,3 kg. Gauge valve set with DN 20 flanges approx. 8 kg.

Torque for body bolts 25 – 30 Nm, cold.

For gauge body, gauge cock and gauge valve part lists, dimensions of glasses and material specifications see pages 18, 37 and 40.

Suggested order specification

Reflex level gauge PN 25

KLINGER material code FS/H, M/H

Gauge glass Borosilicate, thermally prestressed
 Connection gauge body – shut-off rotatable / not rotatable

Shut-off fittings gauge cocks and gauge valves with safety balls

Ordering example:

R 25-DG, IX, FS/H

DN 25 / PN 16

M= 450 mm

R 25-DG

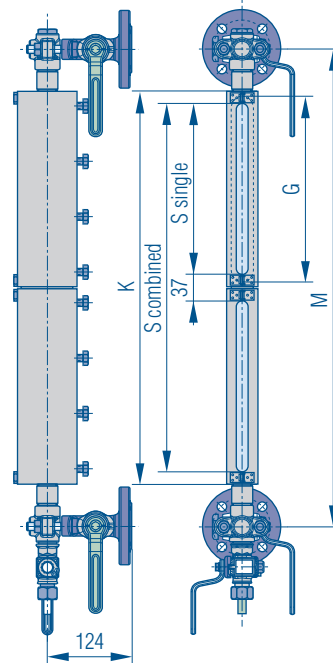

R 25-RAV 947

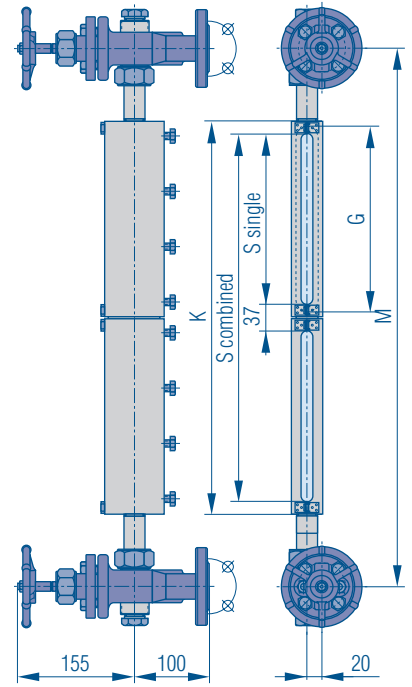

Overall and connection dimensions (mm)

Gauge size	Centre-to-centre distance M min			Body length K	Sight length S	Glass length G	Approx. weight of gauge (kg)
	R 25 DG	R 25 RAV 946/956	R 25 RAV 947/957				
II	215	250	290	153	118	140	3,40
III	240	275	315	178	143	165	3,70
IV	265	300	340	203	168	190	4,10
V	295	330	370	233	198	220	4,80
VI	325	360	400	263	228	250	5,40
VII	355	390	430	293	258	280	5,90
VIII	395	430	470	333	298	320	6,80
IX	415	450	490	353	318	340	7,10
2 x IV	470	505	545	408	373	190	8,40
2 x V	530	565	605	468	433	220	9,90
2 x VI	590	625	665	528	493	250	11,00
2 x VII	650	685	725	588	553	280	12,10
2 x VIII	730	765	805	668	633	320	13,80
2 x IX	770	805	845	708	673	340	14,50
3 x VI	855	890	930	793	758	250	16,50
3 x VII	945	980	1020	883	848	280	18,10
3 x VIII	1065	1100	1140	1003	968	320	20,70
3 x IX	1125	1160	1200	1063	1028	340	21,80
4 x VII	1240	1275	1315	1178	1143	280	24,20
4 x VIII	1400	1435	1475	1338	1303	320	27,70
4 x IX	1480	1515	1555	1418	1383	340	29,10
5 x VII	1535	1570	1610	1473	1438	280	30,20
5 x VIII	1735	1770	1810	1673	1638	320	34,60
5 x IX	1835	1870	1910	1773	1738	340	36,30
6 x VIII	2070	2105	2145	2008	1973	320	41,50
6 x IX	2190	2225	2265	2128	2093	340	43,60
7 x VIII	2405	2440	2480	2343	2308	320	48,40
7 x IX	2545	2580	2620	2483	2448	340	50,90

Shorter distance on request.

Reflex level gauges

Process application

R 100-DG

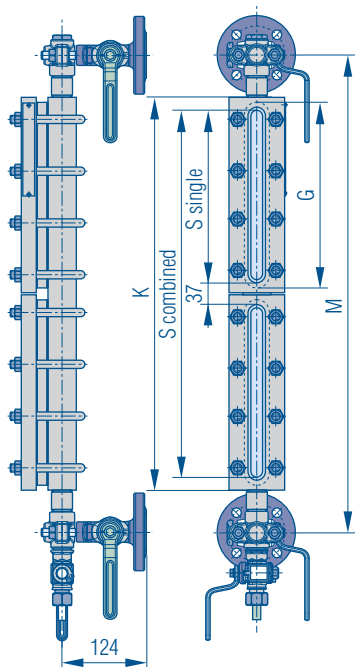

R 100-RAV 947

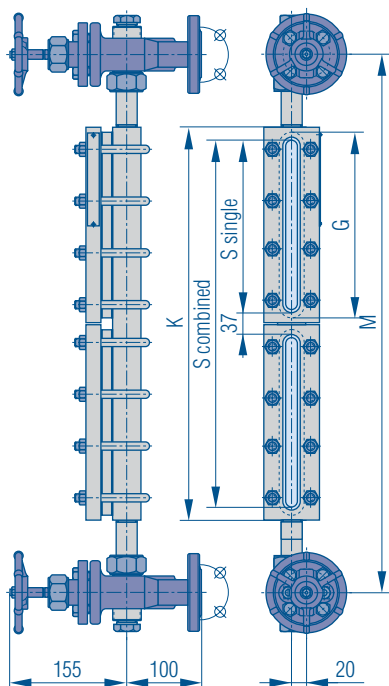

Overall and connection dimensions (mm)

Gauge size	Centre-to-centre distance M min			Body length K	Sight length S	Glass length G	Approx. weight of gauge (kg)
	R 100 DG	R 100 RAV 946/956	R 100 RAV 947/957				
II	215	250	290	153	118	140	3,40
III	240	275	315	178	143	165	3,70
IV	265	300	340	203	168	190	4,10
V	295	330	370	233	198	220	4,80
VI	325	360	400	263	228	250	5,40
VII	355	390	430	293	258	280	5,90
VIII	395	430	470	333	298	320	6,80
IX	415	450	490	353	318	340	7,10
2 x IV	470	505	545	408	373	190	8,40
2 x V	530	565	605	468	433	220	9,90
2 x VI	590	625	665	528	493	250	11,00
2 x VII	650	685	725	588	553	280	12,10
2 x VIII	730	765	805	668	633	320	13,80
2 x IX	770	805	845	708	673	340	14,50
3 x VI	855	890	930	793	758	250	16,50
3 x VII	945	980	1020	883	848	280	18,10
3 x VIII	1065	1100	1140	1003	968	320	20,70
3 x IX	1125	1160	1200	1063	1028	340	21,80
4 x VII	1240	1275	1315	1178	1143	280	24,20
4 x VIII	1400	1435	1475	1338	1303	320	27,70
4 x IX	1480	1515	1555	1418	1383	340	29,10
5 x VII	1535	1570	1610	1473	1438	280	30,20
5 x VIII	1735	1770	1810	1673	1638	320	34,60
5 x IX	1835	1870	1910	1773	1738	340	36,30
6 x VIII	2070	2105	2145	2008	1973	320	41,50
6 x IX	2190	2225	2265	2128	2093	340	43,60
7 x VIII	2405	2440	2480	2343	2308	320	48,40
7 x IX	2545	2580	2620	2483	2448	340	50,90

Shorter distance on request.

Nom. pressure: PN 100, ANSI 600
with gauge cock DG
with gauge valve RAV 946, 956,
947, 957

Construction to KLINGER
material code FS/H, M/H, M

Gauge glass:
Klinger Reflex glass B
Material Borosilicate

Connection gauge body – gauge
valve

Not rotatable: 1/2"-NPT double
nipple gauge cock DG, gauge valve
RAV 946, 956

Rotatable: Union nut and nipple 1/2"-
NPT, gauge valve RAV 947, 957
Seal between nipple and gauge valve:
joint ring.

Connection construction

End connection with gauge cock DG
or gauge valve RAV 946 (see
illustration) and RAV 947 with
handwheel or weighted lever (page 40).
Safety ball in the upper and lower shut-
off fitting.

Gauges without gauge valves:

End, side or back connections with
flanges or female thread.

Vessel connection with flanges or
male thread to all recognized standards.

Weight: Gauges cock set with DN 25
flanges approx. 7,3 kg. Gauge valve set
with DN 20 flanges approx. 8 kg.

Torque for body bolts 50 Nm,
cold.

For gauge body, gauge cock and gauge
valve part lists, dimensions of glasses
and material specifications see pages
18, 37 and 40.

Suggested order specification

Reflex level gauge PN 100

KLINGER material code FS/H, M/H, M

Gauge glass Borosilicate, thermally prestressed
Connection gauge body – shut-off rotatable / not
rotatable

Shut-off fittings gauge cocks and gauge valves
with safety balls

Ordering example:
R 100-DG, IX, FS/H
DN 25 / PN 100
M= 450 mm

R 100*

PN 100

ANSI 600

*) former type
designation MPR



Reflex level gauges

Process application

R 160* Nom. pressure: PN 160, ANSI 900
 with gauge cock DG
 PN 160 with gauge valve RAV 946, 956,
 ANSI 900 947, 957

*) former type designation UPR

Construction to KLINGER
 material code FS/H, M/H, M
Gauge glass:
 Klinger Reflex glass B
 Material Borosilicate

Connection
 gauge body – gauge valve

Not rotatable: 1/2"-NPT double nipple gauge cock DG, gauge valve RAV 946, 956

Rotatable: Union nut and nipple 1/2"-NPT, gauge valve RAV 947, 957
 Seal between nipple and gauge valve: joint ring.

Connection construction

End connection with gauge cock DG or gauge valve RAV 946 (see illustration) and RAV 947 with handwheel or weighted lever (page 40). Safety ball in the upper and lower shut-off fitting.

Gauges without gauge valves:
 End, side or back connections with flanges or female thread.

Vessel connection with flanges or male thread to all recognized standards.

Weight: Gauges cock set with DN 25 flanges approx. 7,3 kg. Gauge valve set with DN 20 flanges approx. 8 kg.

Torque for body bolts 60 Nm, cold.

For gauge body, gauge cock and gauge valve part lists, dimensions of glasses and material specifications see pages 18, 37 and 40.

Suggested order specification

Reflex level gauge PN 160

KLINGER material code FS/H, M/H, M

Gauge glass Borosilicate, thermally prestressed
 Connection gauge body – shut-off rotatable / not rotatable

Shut-off fittings gauge cocks and gauge valves with safety balls

Ordering example:

R 160-RAV 956, 4 x VIII, FS/H
DN 25 / PN 160
M= 1450 mm

R 160-DG

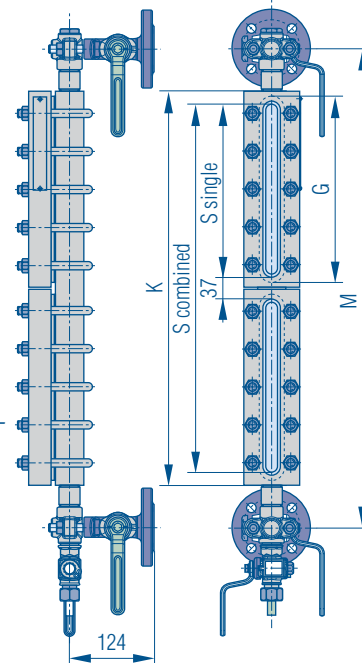

R 160-RAV 947

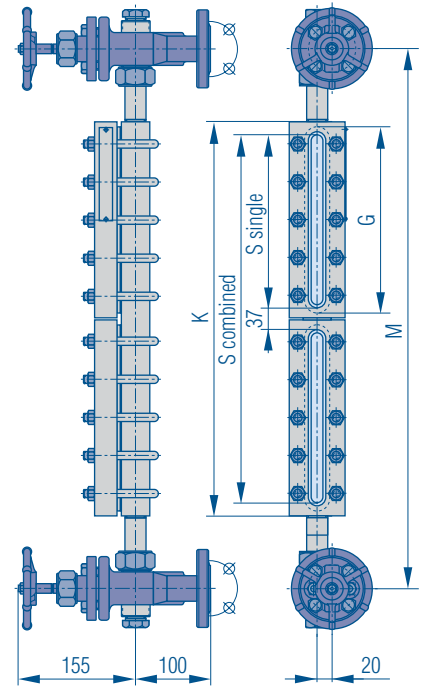

Overall and connection dimensions (mm)

Gauge size	Centre-to-centre distance M min			Body length K	Sight length S	Glass length G	Approx. weight of gauge (kg)
	R 160 DG	R 160 RAV 946/956	R 160 RAV 947/957				
II	215	250	290	153	118	140	3,70
III	240	275	315	178	143	165	4,30
IV	265	300	340	203	168	190	4,90
V	295	330	370	233	198	220	5,60
VI	325	360	400	263	228	250	6,30
VII	355	390	430	293	258	280	7,00
VIII	395	430	470	333	298	320	8,00
IX	415	450	490	353	318	340	8,40
2 x IV	470	505	545	408	373	190	9,90
2 x V	530	565	605	468	433	220	11,50
2 x VI	590	625	665	528	493	250	12,80
2 x VII	650	685	725	588	553	280	14,30
2 x VIII	730	765	805	668	633	320	16,30
2 x IX	770	805	845	708	673	340	17,10
3 x VI	855	890	930	793	758	250	19,20
3 x VII	945	980	1020	883	848	280	21,50
3 x VIII	1065	1100	1140	1003	968	320	24,40
3 x IX	1125	1160	1200	1063	1028	340	25,60
4 x VII	1240	1275	1315	1178	1143	280	28,60
4 x VIII	1400	1435	1475	1338	1303	320	32,50
4 x IX	1480	1515	1555	1418	1383	340	34,20
5 x VII	1535	1570	1610	1473	1438	280	35,80
5 x VIII	1735	1770	1810	1673	1638	320	40,70
5 x IX	1835	1870	1910	1773	1738	340	42,80
6 x VIII	2070	2105	2145	2008	1973	320	48,80
6 x IX	2190	2225	2265	2128	2093	340	51,30
7 x VIII	2405	2440	2480	2343	2308	320	56,90
7 x IX	2545	2580	2620	2483	2448	340	59,90

Shorter distance on request.

Reflex level gauges

Process application

R 250-DG

R 250-RAV 947

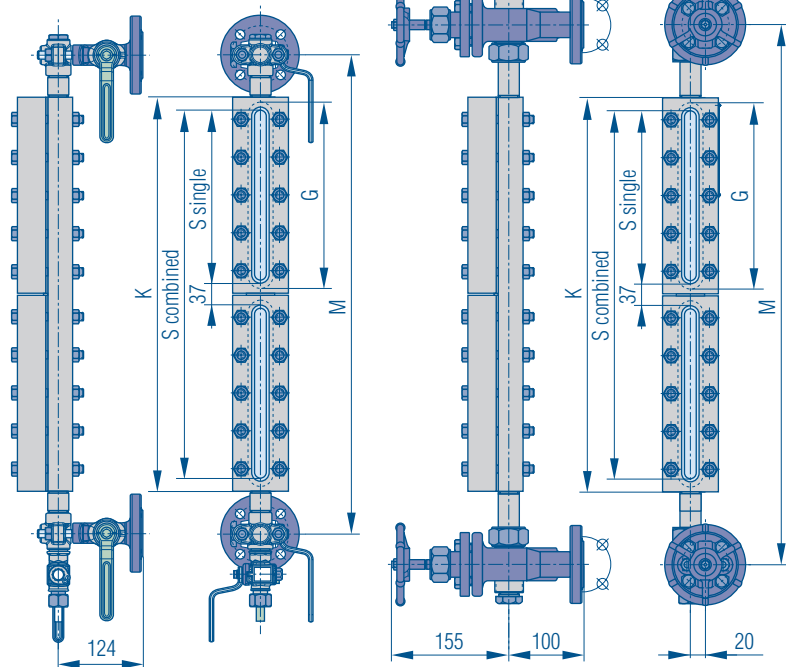

Overall and connection dimensions (mm)

Gauge size	Centre-to-centre distance M min			Body length K	Sight length S	Glass length G	Approx. weight of gauge (kg)
	R 250 DG	R 250 RAV 946/956	R 250 RAV 947/957				
II	215	250	290	153	118	140	3,70
III	240	275	315	178	143	165	4,30
IV	265	300	340	203	168	190	4,90
V	295	330	370	233	198	220	5,60
VI	325	360	400	263	228	250	6,30
VII	355	390	430	293	258	280	7,00
VIII	395	430	470	333	298	320	8,00
IX	415	450	490	353	318	340	8,40
2 x IV	470	505	545	408	373	190	9,90
2 x V	530	565	605	468	433	220	11,50
2 x VI	590	625	665	528	493	250	12,80
2 x VII	650	685	725	588	553	280	14,30
2 x VIII	730	765	805	668	633	320	16,30
2 x IX	770	805	845	708	673	340	17,10
3 x VI	855	890	930	793	758	250	19,20
3 x VII	945	980	1020	883	848	280	21,50
3 x VIII	1065	1100	1140	1003	968	320	24,40
3 x IX	1125	1160	1200	1063	1028	340	25,60
4 x VII	1240	1275	1315	1178	1143	280	28,60
4 x VIII	1400	1435	1475	1338	1303	320	32,50
4 x IX	1480	1515	1555	1418	1383	340	34,20
5 x VII	1535	1570	1610	1473	1438	280	35,80
5 x VIII	1735	1770	1810	1673	1638	320	40,70
5 x IX	1835	1870	1910	1773	1738	340	42,80
6 x VIII	2070	2105	2145	2008	1973	320	48,80
6 x IX	2190	2225	2265	2128	2093	340	51,30
7 x VIII	2405	2440	2480	2343	2308	320	56,90
7 x IX	2545	2580	2620	2483	2448	340	59,90

Shorter distance on request.

Nom. pressure: PN 250, ANSI 900
with gauge cock DG
with gauge valve RAV 946, 956,
947, 957

Construction to KLINGER
material code FS/H, M/H, M

Gauge glass:
Klinger Reflex glass B
Material Borosilicate

Connection
gauge body – gauge valve

Not rotatable: 1/2"-NPT double
nipple gauge cock DG, gauge valve
RAV 946, 956

Rotatable: Union nut and nipple 1/2"-
NPT, gauge valve RAV 947, 957
Seal between nipple and gauge valve:
joint ring.

Connection construction

End connection with gauge cock DG
or gauge valve RAV 946 (see
illustration) and RAV 947 with
handwheel or weighted lever (page 40).
Safety ball in the upper and lower shut-
off fitting.

Gauges without gauge valves:

End, side or back connections with
flanges or female thread.

Vessel connection with flanges or
male thread to all recognized standards.

Weight: Gauges cock set with DN 25
flanges approx. 7,3 kg. Gauge valve set
with DN 20 flanges approx. 8 kg.

Torque for body bolts 60 Nm,
cold.

For gauge body, gauge cock and gauge
valve part lists, dimensions of glasses
and material specifications see pages
18, 37 and 40.

Suggested order specification

Reflex level gauge PN 250

KLINGER material code FS/H, M/H, M

Gauge glass Borosilicate, thermally prestressed
Connection gauge body – shut-off rotatable / not
rotatable

Shut-off fittings gauge cocks and gauge valves
with safety balls

Ordering example:

R 160-RAV 956, 4 x VIII, FS/H
DN 25 / PN 250
M= 1450 mm

R 250*

PN 250

ANSI 1500

*) former type
designation HPR



Reflex level gauges

Process application

UOR Nom. pressure: PN 63, ANSI 400
 with gauge cock DG
 PN 63 with gauge valve RAV 946, 956,
 ANSI 400 947, 957

Construction to KLINGER
 material code FS/H, M/H
Gauge glass:
 Klinger Reflex glass B
 Material Borosilicate

Application range

Primarily for media with boiling point in the low temperature region (low boiling point media).
 Klinger material code:
 FS/H down to -80 °C
 Pressure rating to DIN 2401 – PN 63
 (at -196 °C 63 bar)

Connection

gauge body – gauge valve

Not rotatable: 1/2"-NPT double nipple
 gauge cock DG, gauge valve RAV 946,
 956

Rotatable: Union nut and nipple 1/2"-
 NPT, gauge valve RAV 947, 957
 Seal between nipple and gauge valve:
 joint ring.

Connection construction

End connection with gauge cock DG or
 gauge valve RAV 946/956 (see
 illustration) and RAV 947/957 with
 handwheel or weighted lever (page 32).
 Safety ball in the upper and lower shut-off
 fitting.

Vessel connection with flanges or male
 thread to all recognized standards.

Weight: Gauges cock set with DN 25
 flanges approx. 7,3 kg. Gauge valve set
 with DN 20 flanges approx. 8 kg.

Torque for body bolts 40 Nm, cold.
 For gauge body, gauge cock and gauge
 valve part lists, dimensions of glasses
 and material specifications see pages 18,
 37 and 40.

Suggested order specification

Reflex level gauge PN 63

KLINGER material code FS/H, M/H

Gauge glass Borosilicate

thermally prestressed

Connection gauge body – shut-off rotatable / not
 rotatable

Shut-off fittings gauge cocks and gauge valves
 with safety balls

Ordering example:

UOR-DG, IX, FS/H

DN 25 / PN 63

M= 480 mm

UOR-DG

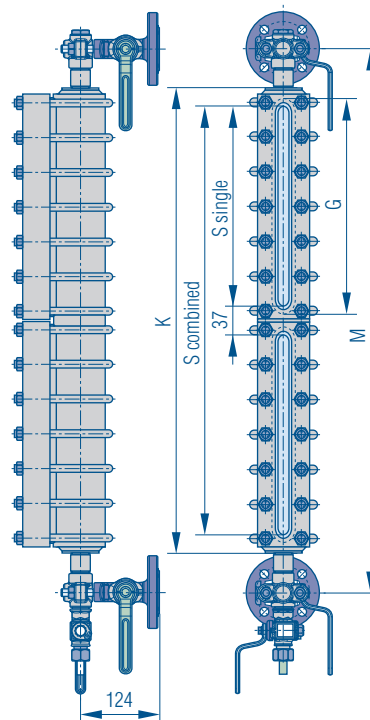

UOR-RAV 947

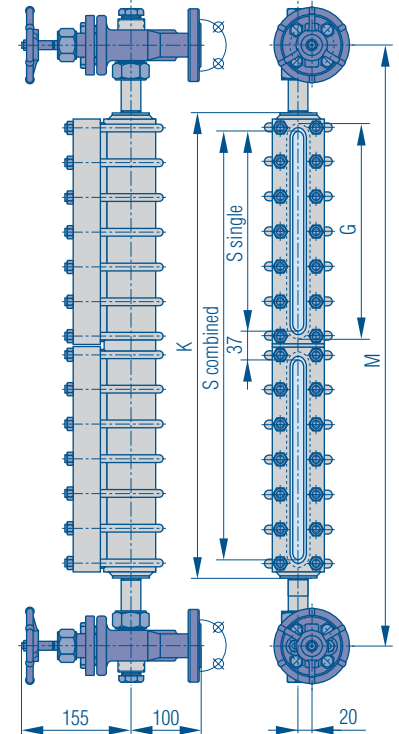

Overall and connection dimensions (mm)

Gauge size	Centre-to-centre distance M min		Body length K	Sight length S	Glass length G	Approx. weight of gauge (kg)
	UOR DG	UOR RAV 946				
II	258	276	168	118	140	5,80
III	283	300	193	143	165	6,80
IV	308	326	218	168	190	7,30
V	338	356	248	198	220	7,80
VI	368	386	278	228	250	8,70
VII	398	416	308	258	280	9,80
VIII	438	456	348	298	320	10,90
IX	458	472	368	318	340	12,00
2 x IV	513	531	423	373	190	14,80
2 x V	573	591	483	433	220	15,60
2 x VI	633	651	543	493	250	17,40
2 x VII	643	711	603	553	280	19,60
2 x VIII	773	791	683	633	320	21,80
2 x IX	813	831	723	673	340	24,00
3 x VI	898	916	808	758	250	26,10
3 x VII	988	1006	898	848	280	29,40
3 x VIII	1108	1126	1018	968	320	32,70
3 x IX	1168	1186	1078	1028	340	36,00
4 x VII	1283	1301	1193	1143	280	39,20
4 x VIII	1443	1461	1353	1303	320	42,50
4 x IX	1523	1541	1433	1383	340	48,00
5 x VII	1578	1596	1488	1438	280	49,00
5 x VIII	1778	1796	1688	1638	320	54,00
5 x IX	1878	1896	1786	1738	340	60,00
6 x VIII	2113	2131	2023	1973	320	64,80
6 x IX	2233	2261	2143	2093	340	72,00

Shorter distance on request.

Reflex level gauges

Process application

A 400

A 400-DVK 2

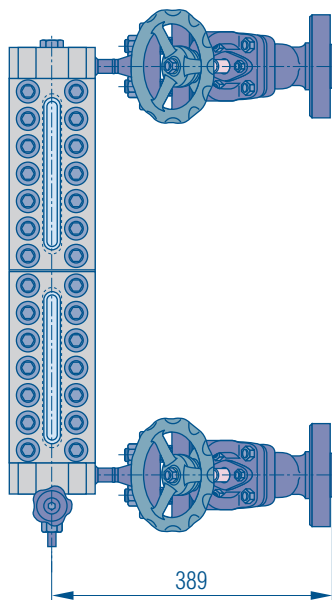
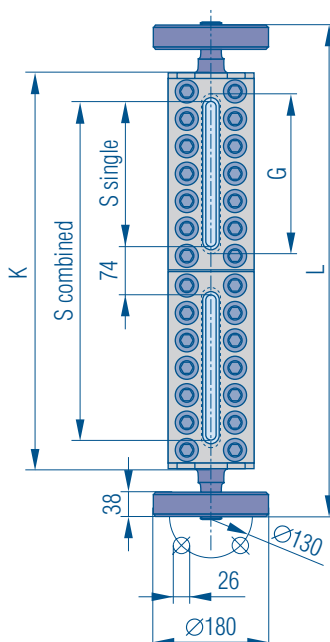

Nominal pressure:
PN 400, ANSI 2500
Construction to KLINGER
material code FS/H
Gauge glass:
Klinger Reflex glass A extra
Material Borosilicate

A 400
PN 400
ANSI 2500
max. 120 °C

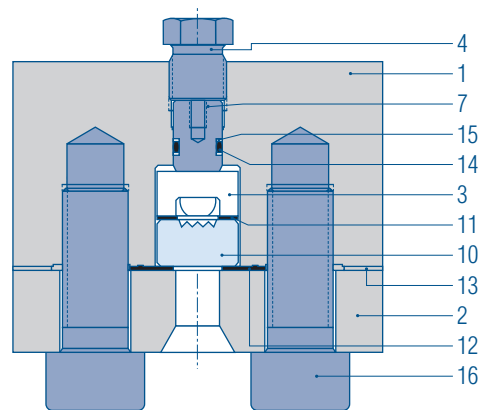

Overall and connection dimensions (mm)

Gauge size	Centre-to-centre distance M min A 400-DVK 2	Total length L	Body length K	Sight length S	Glass length G	Approx. weight of gauge (kg)
III	255	385	231	142	165	35
IV	280	410	256	167	190	38
V	310	440	286	197	220	41
VI	340	470	316	227	250	45
VII	370	500	346	257	280	48
VIII	410	540	386	297	320	52
IX	430	560	406	317	340	54
2 x IV	495	625	471	382	190	66
2 x V	568	698	544	455	220	72
2 x VI	641	771	617	528	250	80
2 x VII	671	801	647	558	280	86
2 x VIII	754	884	730	641	320	94
2 x IX	817	947	793	704	340	98
3 x VI	942	1072	918	829	250	115
3 x VII	972	1102	948	859	280	124
3 x VIII	1098	1228	1047	985	320	136
3 x IX	1204	1334	1180	1091	340	142
4 x VII	1273	1403	1249	1160	280	162
4 x VIII	1442	1572	1418	1329	320	178
4 x IX	1591	1721	1567	1478	340	186
5 x VIII	1786	1916	1762	1673	320	220
5 x IX	1978	2108	1964	1865	340	230
6 x VIII	2130	2260	2106	2017	320	262
6 x IX	2365	2495	2341	2252	340	274
7 x VIII	2474	2604	2450	2361	320	304
7 x IX	2752	2882	2728	2639	340	318

Dimension L is standard, but may be exceeded on request.

Pos.	Part	Materials FS/H
1	Level gauge body	Ck 45 N
2	Cover	Ck 45 N
3	Pressure plate	St 34
4	Pressure screw	9SMn28K
7	Pressure piece	9SMn28K
10	Reflex glass	Borosilicate
11	Sealing gasket	Graphite
12	Frame gasket	Klinger-SIL
13	Cushion joint	Klinger-SIL
14	Sealing ring	119.90
15	Ring	PTFE
16	Ch. Head screw	10.9

Connection gauge body – gauge valve

Screwed of flanges to DN 25 PN 400 with lens groove DN 15 to DIN 2696 (see illustration).
The gauge may also be fitted with type DVK 2 gauge valves mounted directly on the piece.

Torque for body bolts 350 Nm.

Torque for pressure screws 90 Nm, cold.

For gauge and gauge valve part lists, dimensions of glasses and material specifications see pages 18, 37 and 40.

Suggested order specification

Reflex level gauge PN 400

KLINGER material code FS/H

Gauge glass Borosilicate

thermally prestressed

Ordering example:

A 400, IX
DN 25 / PN 400
M= 456 mm



Transparent level gauges

Process application

T 50* *Nom. pressure: PN 40, ANSI 300*
PN 40 *with gauge cock DG*
ANSI 300 *with gauge valve RAV 946, 956, 947, 957*

*) former type designation MPT

Construction to KLINGER
material code FS/H, M/H, M
Gauge glass:
Klinger Transparent glass B
Material Borosilicate

Connection
gauge body – gauge valve

Not rotatable: 1/2"-NPT double nipple gauge cock DG, gauge valve RAV 946, 956

Rotatable: Union nut and nipple 1/2"-NPT, gauge valve RAV 947, 957
 Seal between nipple and gauge valve: joint ring.

Connection construction

End connection with gauge cock DG or gauge valve RAV 946 (see illustration) and RAV 947 with handwheel or weighted lever (page 40). Safety ball in the upper and lower shut-off fitting.

Gauges without gauge valves: End, side or back connections with flanges or female thread.

Vessel connection with flanges or male thread to all recognized standards.

Weight: Gauges cock set with DN 25 flanges approx. 7,3 kg. Gauge valve set with DN 25 flanges approx. 8 kg.

Torque for body bolts 50 Nm, cold.

For gauge body, gauge cock and gauge valve part lists, dimensions of glasses and material specifications see pages 19, 37 and 40.

Suggested order specification

Transparent level gauge PN 40

KLINGER material code FS/H, M/H, M
 Gauge glass Borosilicate, thermally prestressed
 Connection gauge body – shut-off rotatable / not rotatable

Shut-off fittings gauge cocks and gauge valves with safety balls

Ordering example:
T 50-DG, 2 x VIII, M/H,
DN 25 / PN 40
M= 760 mm

T 50-DG

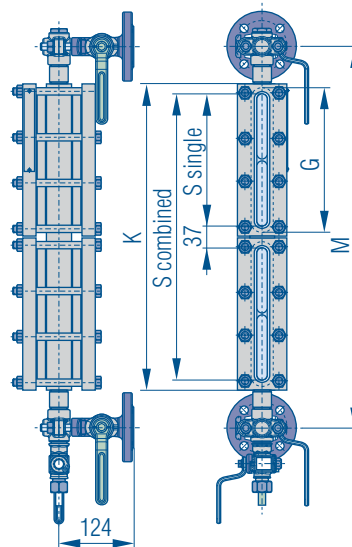

T 50-RAV 947

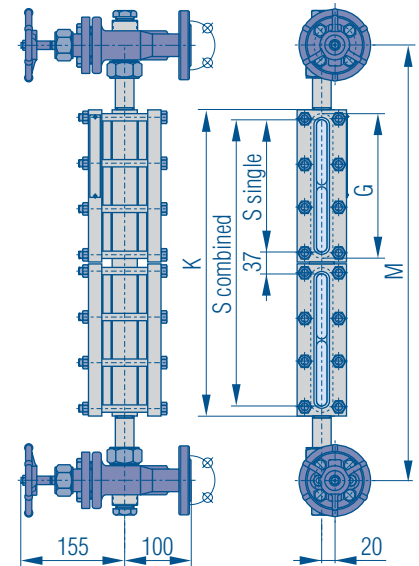

Overall and connection dimensions (mm)

Gauge size	Centre-to-centre distance M min			Body length K	Sight length S	Glass length G	Approx. weight of gauge (kg)
	T 50 DG	T 50 RAV 946/956	T 50 RAV 947/957				
II	215	250	290	153	118	140	4,40
III	240	275	315	178	143	165	5,30
IV	265	300	340	203	168	190	6,00
V	295	330	370	233	198	220	6,90
VI	325	360	400	263	228	250	7,70
VII	355	390	430	293	258	280	8,50
VIII	395	430	470	333	298	320	9,70
IX	415	450	490	353	318	340	10,20
2 x IV	470	505	545	408	373	190	12,00
2 x V	530	565	605	468	433	220	14,00
2 x VI	590	625	665	528	493	250	15,50
2 x VII	650	685	725	588	553	280	17,10
2 x VIII	730	765	805	668	633	320	19,60
2 x IX	770	805	845	708	673	340	20,50
3 x VI	855	890	930	793	758	250	23,30
3 x VII	945	980	1020	883	848	280	25,70
3 x VIII	1065	1100	1140	1003	968	320	29,40
3 x IX	1125	1160	1200	1063	1028	340	30,80
4 x VII	1240	1275	1315	1178	1143	280	34,30
4 x VIII	1400	1435	1475	1338	1303	320	38,90
4 x IX	1480	1515	1555	1418	1383	340	41,10
5 x VII	1535	1570	1610	1473	1438	280	42,80
5 x VIII	1735	1770	1810	1673	1638	320	48,90
5 x IX	1835	1870	1910	1773	1738	340	51,40
6 x VIII	2070	2105	2145	2008	1973	320	58,70
6 x IX	2190	2225	2265	2128	2093	340	61,70
7 x VIII	2405	2440	2480	2343	2308	320	68,50
7 x IX	2545	2580	2620	2483	2448	340	72,00

Shorter distance on request.

Transparent level gauges

Process application

T 100-DG

T 100-RAV 947

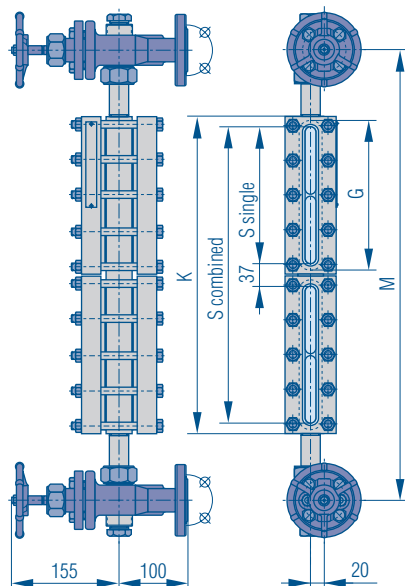
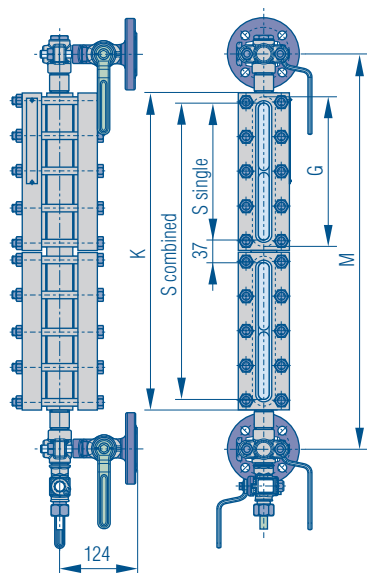

Overall and connection dimensions (mm)

Gauge size	Centre-to-centre distance M min			Body length K	Sight length S	Glass length G	Approx. weight of gauge (kg)
	T 100 DG	T 100 RAV 946/956	T 100 RAV 947/957				
II	215	250	290	153	118	140	5,50
III	240	275	315	178	143	165	6,40
IV	265	300	340	203	168	190	7,30
V	295	330	370	233	198	220	8,40
VI	325	360	400	263	228	250	9,40
VII	355	390	430	293	258	280	10,40
VIII	395	430	470	333	298	320	11,90
IX	415	450	490	353	318	340	12,50
2 x IV	470	505	545	408	373	190	15,40
2 x V	530	565	605	468	433	220	17,90
2 x VI	590	625	665	528	493	250	19,80
2 x VII	650	685	725	588	553	280	22,20
2 x VIII	730	765	805	668	633	320	25,20
2 x IX	770	805	845	708	673	340	36,40
3 x VI	855	890	930	793	758	250	29,70
3 x VII	945	980	1020	883	848	280	33,20
3 x VIII	1065	1100	1140	1003	968	320	37,80
3 x IX	1125	1160	1200	1063	1028	340	39,70
4 x VII	1240	1275	1315	1178	1143	280	44,30
4 x VIII	1400	1435	1475	1338	1303	320	50,40
4 x IX	1480	1515	1555	1418	1383	340	52,90
5 x VII	1535	1570	1610	1473	1438	280	55,40
5 x VIII	1735	1770	1810	1673	1638	320	63,00
5 x IX	1835	1870	1910	1773	1738	340	66,10
6 x VIII	2070	2105	2145	2008	1973	320	75,60
6 x IX	2190	2225	2265	2128	2093	340	79,30
7 x VIII	2405	2440	2480	2343	2308	320	88,20
7 x IX	2545	2580	2620	2483	2448	340	92,60

Shorter distance on request.

Nom. pressure: PN 100, ANSI 600 with gauge cock DG with gauge valve RAV 946, 956, 947, 957

Construction to KLINGER material code FS/H, M/H, M Gauge glass: Klinger Transparent glass B Material Borosilicate

Connection gauge body – gauge valve

Not rotatable: 1/2"-NPT double nipple gauge cock DG, gauge valve RAV 946, 956

Rotatable: Union nut and nipple 1/2"-NPT, gauge valve RAV 947, 957

Seal between nipple and gauge valve: joint ring.

Connection construction

End connection with gauge cock DG or gauge valve RAV 946 (see illustration) and RAV 947 with handwheel or weighted lever (page 40). Safety ball in the upper and lower shut-off fitting.

Gauges without gauge valves:

End, side or back connexions with flanges or female thread.

Vessel connection with flanges or male thread to all recognized standards.

Weight: Gauges cock set with DN 25 flanges approx. 7,3 kg. Gauge valve set with DN 25 flanges approx. 8 kg.

Torque for body bolts 55 Nm, cold.

For gauge body, gauge cock and gauge valve part lists, dimensions of glasses and material specifications see pages 19, 37 and 40.

Suggested order specification Transparent level gauge PN 100

KLINGER material code FS/H, M/H, M Gauge glass Borosilicate, thermally prestressed Connection gauge body – shut-off rotatable / not rotatable Shut-off fittings gauge cocks and gauge valves with safety balls

Ordering example:
T 100-RAV 957, IX, M
DN 25 / PN 100
M= 500 mm

T 100*

PN 100
ANSI 600

*) former type designation UPT



Transparent level gauges

Process application

T 160* Nom. pressure: PN 160, ANSI 900
with gauge cock DG
PN 160 with gauge valve RAV 946, 956,
ANSI 900 947, 957

*) former type designation XDT

Construction to KLINGER
material code FS/H, M/H, M
Gauge glass:
Klinger Transparent glass B
Material Borosilicate

Connection
gauge body – gauge valve

Not rotatable: 1/2"-NPT double
nipple gauge cock DG, gauge valve
RAV 946, 956

Rotatable: Union nut and nipple 1/2"-
NPT, gauge valve RAV 947, 957
Seal between nipple and gauge valve:
joint ring.

Connection construction

End connection with gauge cock DG
or gauge valve RAV 946 (see
illustration) and RAV 947 with
handwheel or weighted lever (page 40).
Safety ball in the upper and lower shut-
off fitting.

Gauges without gauge valves:
End, side or back connexions with
flanges or female thread.

Vessel connection with flanges or
male thread to all recognized standards.

Weight: Gauges cock set with DN 25
flanges approx. 7,3 kg. Gauge valve set
with DN 25 flanges approx. 8 kg.

Torque for body bolts 65 Nm,
cold.

For gauge body, gauge cock and gauge
valve part lists, dimensions of glasses
and material specifications see pages
19, 37 and 40.

Suggested order specification
Transparent level gauge PN 160

KLINGER material code FS/H, M/H, M
Gauge glass Borosilicate, thermally prestressed
Connection gauge body – shut-off rotatable / not
rotatable

Shut-off fittings gauge cocks and gauge valves
with safety balls

Ordering example:
T 160-RAV 957, IX, M
DN 25 / PN 160
M= 500 mm

T 160-DG

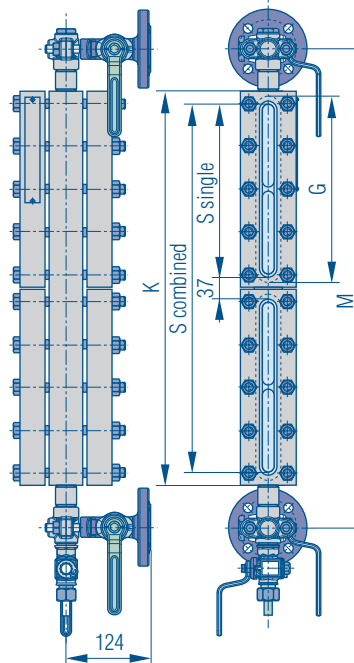

T 160-RAV 947

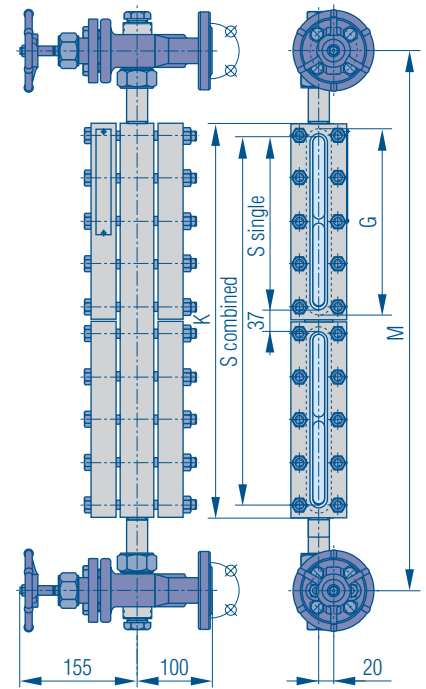

Overall and connection dimensions (mm)

Gauge size	Centre-to-centre distance M min			Body length K	Sight length S	Glass length G	Approx. weight of gauge (kg)
	T 160 DG	T 160 RAV 946,956	T 160 RAV 947/957				
II	215	250	290	153	118	140	5,50
III	240	275	315	178	143	165	6,40
IV	265	300	340	203	168	190	7,30
V	295	330	370	233	198	220	8,40
VI	325	360	400	263	228	250	9,40
VII	355	390	430	293	258	280	10,40
VIII	395	430	470	333	298	320	11,90
IX	415	450	490	353	318	340	12,50
2 x IV	470	505	545	408	373	190	15,40
2 x V	530	565	605	468	433	220	17,90
2 x VI	590	625	665	528	493	250	19,80
2 x VII	650	685	725	588	553	280	22,20
2 x VIII	730	765	805	668	633	320	25,20
2 x IX	770	805	845	708	673	340	36,40
3 x VI	855	890	930	793	758	250	29,70
3 x VII	945	980	1020	883	848	280	33,20
3 x VIII	1065	1100	1140	1003	968	320	37,80
3 x IX	1125	1160	1200	1063	1028	340	39,70
4 x VII	1240	1275	1315	1178	1143	280	44,30
4 x VIII	1400	1435	1475	1338	1303	320	50,40
4 x IX	1480	1515	1555	1418	1383	340	52,90
5 x VII	1535	1570	1610	1473	1438	280	55,40
5 x VIII	1735	1770	1810	1673	1638	320	63,00
5 x IX	1835	1870	1910	1773	1738	340	66,10
6 x VIII	2070	2105	2145	2008	1973	320	75,60
6 x IX	2190	2225	2265	2128	2093	340	79,30
7 x VIII	2405	2440	2480	2343	2308	320	88,20
7 x IX	2545	2580	2620	2483	2448	340	92,60

Shorter distance on request.

Transparent level gauges

Gauge cocks

T 250-DG

T 250-RAV 947

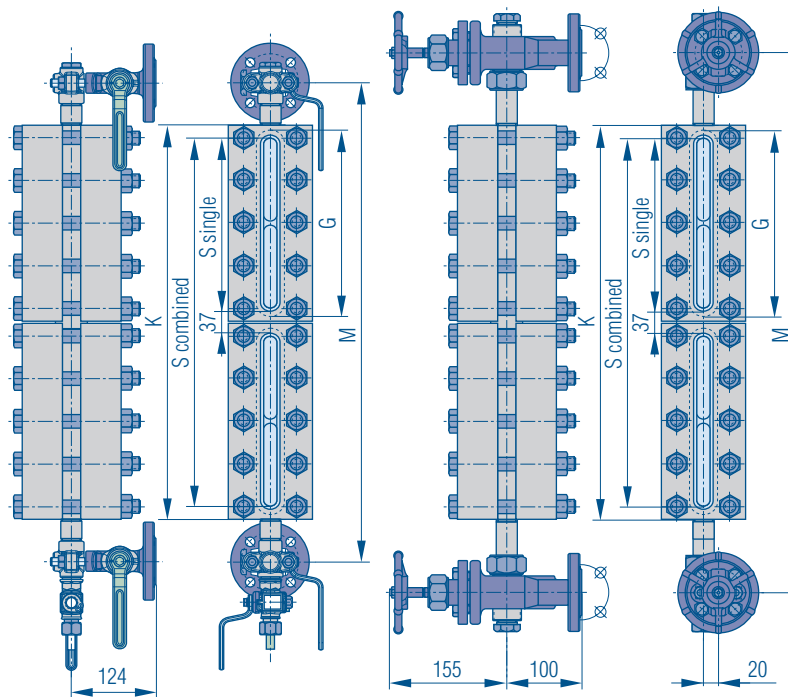

Nom. pressure: PN 250, ANSI 1500
with gauge cock DG
with gauge valve RAV 946, 956,
947, 957

T 250*

PN 250

ANSI 1500

**) former type
 designation HPT*

Construction to KLINGER
material code FS/H, M/H, M
Gauge glass:
Klinger Transparent glass B
Material Borosilicate

Connection
gauge body – gauge valve

Not rotatable: 1/2"-NPT double
 nipple gauge cock DG, gauge valve
 RAV 946, 956

Rotatable: Union nut and nipple 1/2"-
 NPT, gauge valve RAV 947, 957
 Seal between nipple and gauge valve:
 joint ring.

Connection construction

End connection with gauge cock DG
 or gauge valve RAV 946 (see
 illustration) and RAV 947 with
 handwheel or weighted lever (page 40).
 Safety ball in the upper and lower shut-
 off fitting.

Gauges without gauge valves:

End, side or back connexions with
 flanges or female thread.

Vessel connection with flanges or
 male thread to all recognized standards.

Weight: Gauges cock set with DN 25
 flanges approx. 7,3 kg. Gauge valve set
 with DN 25 flanges approx. 8 kg.

Torque for body bolts 100 Nm,
cold.

For gauge body, gauge cock and gauge
 valve part lists, dimensions of glasses
 and material specifications see pages
 19, 37 and 40.

Suggested order specification

Transparent level gauge PN 250

KLINGER material code FS/H, M/H, M

Gauge glass Borosilicate, thermally prestressed
 Connection gauge body – shut-off rotatable / not
 rotatable

Shut-off fittings gauge cocks and gauge valves
 with safety balls

Ordering example:

T 250-RAV 957, IX, M

DN 25 / PN 250

M= 500 mm

Overall and connection dimensions (mm)

Gauge size	Centre-to-centre distance M min			Body length K	Sight length S	Glass length G	Approx. weight of gauge (kg)
	T 250 DG	T 250 RAV 946/956	T 250 RAV 947/957				
II	215	250	290	153	118	140	5,50
III	240	275	315	178	143	165	6,40
IV	265	300	340	203	168	190	7,30
V	295	330	370	233	198	220	8,40
VI	325	360	400	263	228	250	9,40
VII	355	390	430	293	258	280	10,40
VIII	395	430	470	333	298	320	11,90
IX	415	450	490	353	318	340	12,50
2 x IV	470	505	545	408	373	190	15,40
2 x V	530	565	605	468	433	220	17,90
2 x VI	590	625	665	528	493	250	19,80
2 x VII	650	685	725	588	553	280	22,20
2 x VIII	730	765	805	668	633	320	25,20
2 x IX	770	805	845	708	673	340	36,40
3 x VI	855	890	930	793	758	250	29,70
3 x VII	945	980	1020	883	848	280	33,20
3 x VIII	1065	1100	1140	1003	968	320	37,80
3 x IX	1125	1160	1200	1063	1028	340	39,70
4 x VII	1240	1275	1315	1178	1143	280	44,30
4 x VIII	1400	1435	1475	1338	1303	320	50,40
4 x IX	1480	1515	1555	1418	1383	340	52,90
5 x VII	1535	1570	1610	1473	1438	280	55,40
5 x VIII	1735	1770	1810	1673	1638	320	63,00
5 x IX	1835	1870	1910	1773	1738	340	66,10
6 x VIII	2070	2105	2145	2008	1973	320	75,60
6 x IX	2190	2225	2265	2128	2093	340	79,30
7 x VIII	2405	2440	2480	2343	2308	320	88,20
7 x IX	2545	2580	2620	2483	2448	340	92,60

Shorter distance on request.



Transparent level gauges

Process application

UOT
PN 63
ANSI 400

Nom. pressure: PN 63, ANSI 400
with gauge cock DG
with gauge valve RAV 946, 956,
947, 957

Construction to KLINGER
material code FS/H, M/H

Gauge glass:
Klinger Transparent glass B
Material Borosilicate

Application range

Primarily for media with boiling point in the low temperature region (low boiling point media).
 Klinger material code:
 FS/H down to -80 °C
 Pressure rating to DIN 2401 – PN 63
 (at -196 °C 63 bar)

Connection

gauge body – gauge valve

Not rotatable: 1/2"-NPT double nipple
 gauge cock DG, gauge valve RAV 946,
 956

Rotatable: Union nut and nipple
 1/2"-NPT, gauge valve RAV 947, 957
 Seal between nipple and gauge valve:
 joint ring.

Connection construction

End connection with gauge cock DG
 or gauge valve RAV 946/947 (see
 illustration) and RAV 956/957 with
 handwheel or weighted lever (page 32).
 Safety ball in the upper and lower shut-off
 fitting.

Vessel connection with flanges or male
 thread to all recognized standards.

Weight: Gauges cock set with DN 25
 flanges approx. 7,3 kg. Gauge valve set
 with DN 25 flanges approx. 8 kg.

Torque for body bolts 40 Nm, cold.
 For gauge body, gauge cock and gauge
 valve part lists, dimensions of glasses
 and material specifications see pages 19,
 37 and 40.

Suggested order specification

Transparent level gauge PN 63

KLINGER material code FS/H, M/H
 Gauge glass Borosilicate, thermally prestressed
 Connection gauge body – shut-off rotatable / not
 rotatable
 Shut-off fittings gauge cocks and gauge valves
 with safety balls

Ordering example:

UOT-RAV 946, 2 x V, M/H
DN 25 / PN 63
M= 600 mm

UOT-DG

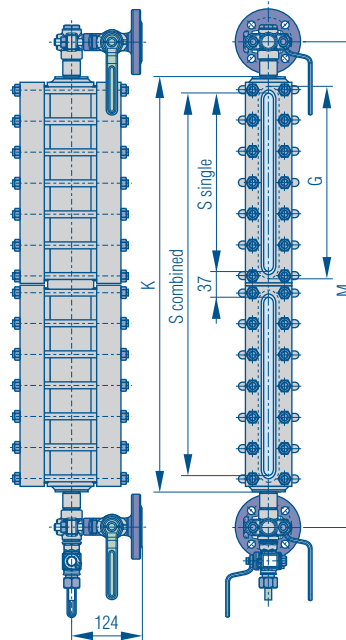

UOT-RAV 947

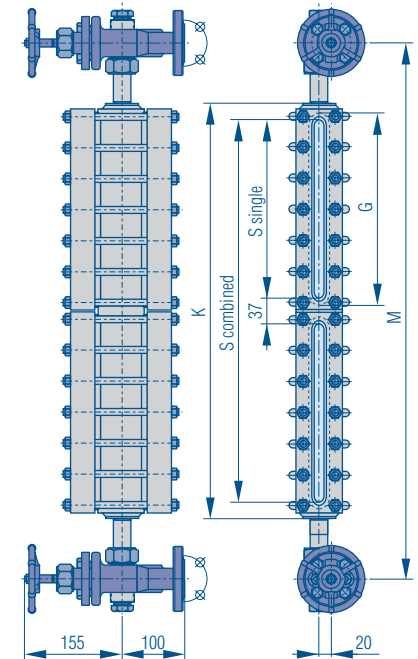

Overall and connection dimensions (mm)

Gauge size	Centre-to-centre distance M min		Body length K	Sight length S	Glass length G	Approx. weight of gauge (kg)
	UOT DG	UOT RAV 946				
II	258	276	168	118	140	14,10
III	283	300	193	143	165	15,60
IV	308	326	218	168	190	17,00
V	338	356	248	198	220	18,80
VI	368	386	278	228	250	20,60
VII	398	416	308	258	280	22,30
VIII	438	456	348	298	320	24,70
IX	458	472	368	318	340	25,80
2 x IV	513	531	423	373	190	29,10
2 x V	573	591	483	433	220	32,60
2 x VI	633	651	543	493	250	36,10
2 x VII	643	711	603	553	280	39,70
2 x VIII	773	791	683	633	320	44,40
2 x IX	813	831	723	673	340	46,70
3 x VI	898	916	808	758	250	51,70
3 x VII	988	1006	898	848	280	57,00
3 x VIII	1108	1126	1018	968	320	62,10
3 x IX	1168	1186	1078	1028	340	67,70
4 x VII	1283	1301	1193	1143	280	74,40
4 x VIII	1443	1461	1353	1303	320	83,80
4 x IX	1523	1541	1433	1383	340	88,50
5 x VII	1578	1596	1488	1438	280	91,70
5 x VIII	1778	1796	1688	1638	320	103,50
5 x IX	1878	1896	1786	1738	340	109,40
6 x VIII	2113	2131	2023	1973	320	123,20
6 x IX	2233	2261	2143	2093	340	130,30

Shorter distance on request.

Glass tube level gauges

Steam and process application

Nominal pressure:
PN 16, 120 °C process
10 bar, 185 °C steam
Construction to KLINGER
material code FS/H, M/H, M

R-D
PN 16
10 bar
185 °C / 120 °C

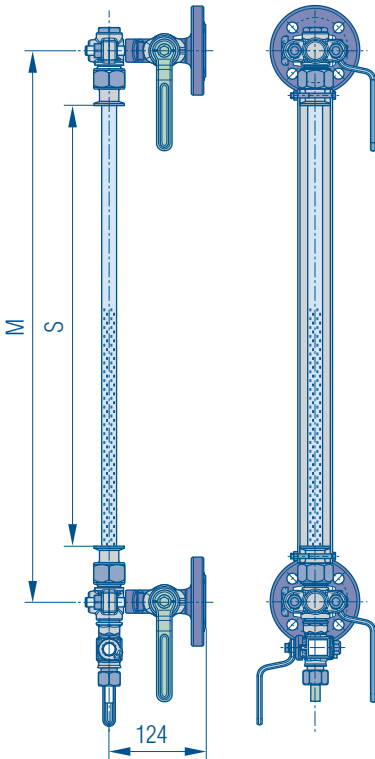

$S = M - 125$
 Sight length = centre-to-centre – 125 mm

$L = M - 25$
 Glass tube length = centre-to-centre – 25 mm

Connection

gauge body – gauge cock

Rotatable (360°) with glass tube o. D. 16 mm.

Vessel connections
 Flanged – Male threaded

Union piece
 For center-to-center distances exceeding 1500 – 2000 mm and multiples thereof, one or more union pieces must be used.

Glass protection
 On request, we can supply a glass tube protection in carbon steel.

Klinger R-D glass tube level gauge, suitable for shut-off fittings: soft sealed gauge cocks, model D (with silicon packing).

Safety balls top and bottom as standard.

Accessories
 Vent cocks
 Calibrated scale

Union piece

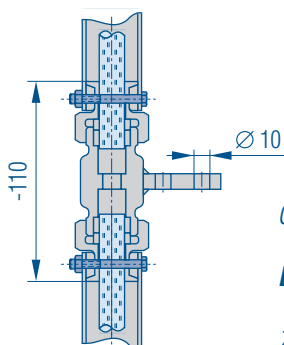

Glass tube length (with union piece):

$$L_{\text{glass}} = \frac{M - (15 \times Z) - 25}{Z + 1} \text{ mm}$$

Z = number of union pieces



Reflex and transparent level gauges

Process application

UWR / UWT

USR / UST

PN 100

ANSI 600

max. 400 °C

Nominal pressure: PN 100, ANSI 600

Construction to KLINGER

material code FS/H, M/H, M

Gauge glass:

UWR / UWT: Klinger reflex glass B

UWT / UST: Klinger transparent glass

Connections

ready to be connected with vessel by weldings..

Radius (UWR – UWT)

On request for level gauges UWR – UWT can be carried out a radius machining on level gauge body to suit it to the vessel radius.

Accessories

calibrated scale
glass protection
non-frosting block

Gauge size	Body length K	Sight length S
I	128	93
II	153	118
III	178	143
IV	203	168
V	233	198
VI	263	228
VII	293	258
VIII	333	298
IX	353	318

Pos.	Part	Materials *)	
		FS/H	M/H
1	Level gauge body	A 105	A 316
2	Cover	A 105	A 105
5	Glass	Borosilicate	Borosilicate
6	Sealing gasket	Graphite	Graphite
7	Cushion joint	Klinger-Sil	Klinger-Sil
8	Bolt (USR / UST)	8.8	8.8
8	Bolt (UWR / UWT)	A 193 B7	A 193 B7
9	Nut (UWR / UWT)	A 194 2H	A 194 2H

UWR / UWT

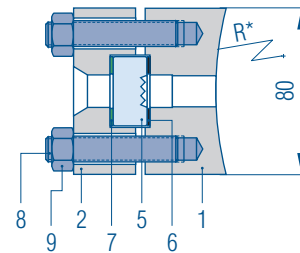
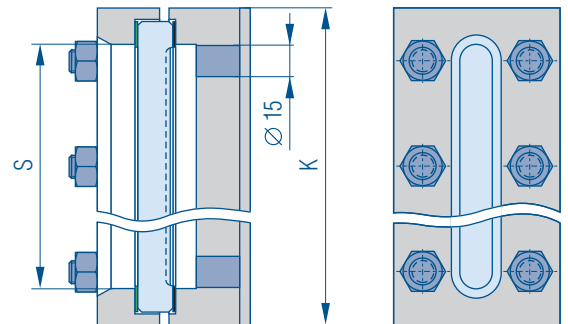

**UWR / UWT
torque for
gauge bolts
50 Nm**

USR / UST

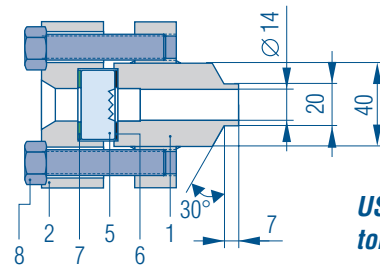
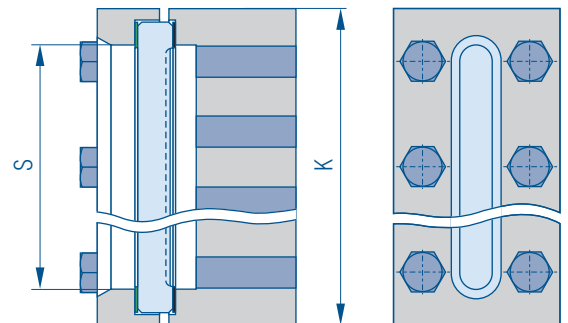

**USR / UST
torque for
gauge bolts
40 Nm**

Reflex and transparent gauge glasses

Technical data

Reflex glasses A, B, H

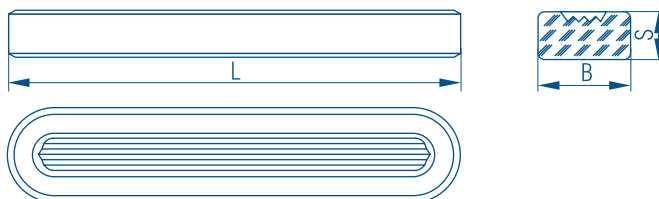

Reflex glasses

Overall dimension (mm)

Size	Type A			Weight g/piece	Type B			Weight g/piece	Type H			Weight g/piece
	L	B	S		L	B	S		L	B	S	
0	-	-	-	-	95	34	17	110	-	-	-	-
I	115	30	17	118	115	34	17	132	115	34	22	176
II	140	30	17	146	140	34	17	162	140	34	22	214
III	165	30	17	176	165	34	17	195	165	34	22	254
IV	190	30	17	200	190	34	17	228	190	34	22	294
V	220	30	17	237	220	34	17	264	220	34	22	344
VI	250	30	17	265	250	34	17	301	250	34	22	392
VII	280	30	17	303	280	34	17	338	280	34	22	445
VIII	320	30	17	334	320	34	17	387	320	34	22	503
IX	340	30	17	359	340	34	17	410	340	34	22	536
X	-	-	-	-	370	34	17	461	-	-	-	-

KLINGER gauges glasses Applicational range reflex glasses	Type A 1)		Type B 1)		Type H 1)	
	bar	°C	bar	°C	bar	°C
For media with no significant glass attack, e.g. oils, hydrocarbons	400	120	265	120	300	120
	150	400	180	400	200	400
	0-10	430	0-10	430	0-10	430
For media with significant glass attack, e.g. saturated steam, HPHW, alkalis	35	243	35	243	42 ²⁾	253

1) Glass types to OeNORM M 7354 or DIN 7081.

2) For steam pressures above 35 bar we recommend the use of transparent glasses with mica shields.

Transparent glasses A, B, H, TA 28



Transparent glasses

Overall dimension (mm)

Size	Type A			Weight g/piece	Type B			Weight g/piece	Type H			Weight g/piece	Type TA 28			Weight g/piece
	L	B	S		L	B	S		L	B	S		L	B	S	
0	-	-	-	-	95	34	17	110	-	-	-	-	-	-	-	-
I	115	30	17	118	115	34	17	132	115	34	22	176	113	27,6	16,8	114
II	140	30	17	146	140	34	17	162	140	34	22	214	-	-	-	-
III	165	30	17	176	165	34	17	195	165	34	22	254	163	27,6	16,8	168
IV	190	30	17	200	190	34	17	228	190	34	22	294	188	27,6	16,8	194
V	220	30	17	237	220	34	17	264	220	34	22	344	218	27,6	16,8	226
VI	250	30	17	265	250	34	17	301	250	34	22	392	248	27,6	16,8	258
VII	280	30	17	303	280	34	17	338	280	34	22	445	278	27,6	16,8	290
VIII	320	30	17	334	320	34	17	387	320	34	22	503	318	27,6	16,8	334
IX	340	30	17	359	340	34	17	410	340	34	22	536	338	27,6	16,8	356
X	-	-	-	-	370	34	17	461	-	-	-	-	-	-	-	-

KLINGER gauges glasses Applicational range transparent glasses	Type A 1)		Type B 1)		Type H		Type TA 28 4)	
	bar	°C	bar	°C	bar	°C	bar	°C
For media with no significant glass attack, e.g. oils, hydrocarbons	240	120	290	120	340	120	-	-
	160	400	200	400	230	400	-	-
	0-10	430	0-10	430	0-10	430	-	-
For media with significant glass attack, e.g. saturated steam, HPHW, alkalis	2)	-	2)	-	2)	-	3)	-
	35	243	35	243	42	253	120	324
	70	300	85	300	85	300	180	356

1) Glass types to OeNORM M 7354 or DIN 7081.

2) For steam pressures above 35 bar we recommend the use of transparent glasses with mica shields.

3) For steam pressures above 120 bar only TA 28 glasses, size I, may be used.

4) TA glasses may only be used with mica shields.



Sealing and cushion gasket & mica shields for reflex and transparent gauge glasses

Sealings

Sealing gasket, cushion gasket made from asbestos-free material

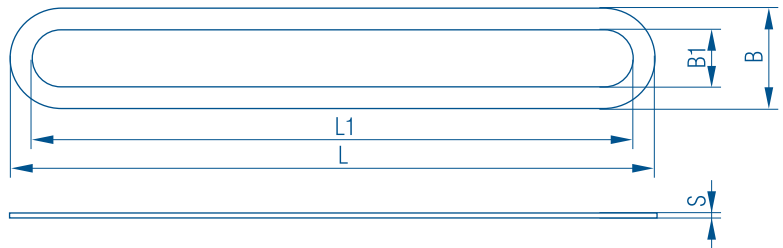

Overall dimension (mm)

Size	Type A				Type B/H				Sealing gasket and protective gasket 1) TA 28				Cushion gasket 2) TA 28			
	L	L1	B	B1	L	L1	B	B1	L	L1	B	B1	L	L1	B	B1
0	95	70	30	15	95	70	34	15	-	-	-	-	-	-	-	-
I	115	90	30	15	115	90	34	15	133	97	47	19	112	97	27	17
II	140	115	30	15	140	115	34	15	-	-	-	-	-	-	-	-
III	165	140	30	15	165	140	34	15	183	147	47	19	162	147	27	17
IV	190	165	30	15	190	165	34	15	208	172	47	19	187	172	27	17
V	220	195	30	15	220	195	34	15	238	202	47	19	217	202	27	17
VI	250	225	30	15	250	225	34	15	268	232	47	19	247	232	27	17
VII	280	255	30	15	280	255	34	15	298	262	47	19	277	262	27	17
VIII	320	295	30	15	320	295	34	15	338	302	47	19	317	302	27	17
IX	340	315	30	15	340	315	34	15	358	322	47	19	337	322	27	17

Sealing and cushion gasket s=1,5 mm

1) Protective gasket s=0,5 mm

2) Cushion gasket s=0,5 mm

Mica shields

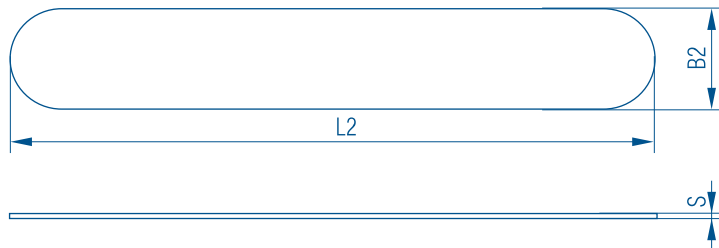

Overall dimension (mm)

Size	Type A		Type B/H		Type TA 28	
	L2	B2	L2	B2	L2	B2
0	95	30	95	34	-	-
I	115	30	115	34	133	47 ¹⁾
II	140	30	140	34	-	-
III	165	30	165	34	183	47 ²⁾
IV	190	30	190	34	208	47 ²⁾
V	220	30	220	34	238	47 ²⁾
VI	250	30	250	34	268	47 ²⁾
VII	280	30	280	34	298	47 ²⁾
VIII	320	30	320	34	338	47 ²⁾
IX	340	30	340	34	358	47 ²⁾

s=0,15-0,20

s=0,15-0,20

¹⁾ s=0,60 ²⁾ s=0,30-0,40

Material

A and B micas: stained first quality

TA 28 micas: stained A quality

KEL-F shields

Size like mica shields

Type B/H standard thickness = 1 mm

Liquid level gauges

Shut-off fittings

Shut-off fittings gauge valve DVK-2

Shut-off fittings for high pressures and high temperatures. The piston material is high-alloy, hardened steel. The connection to the gauge is made by a connecting piece with two flanges.

Standard version with safety ball in the two gauge valves. Standard operation by handwheel, special version with chain-wheel operation. Quick open/shut operation is not possible with DVK 2 gauge valves.

DVK 2

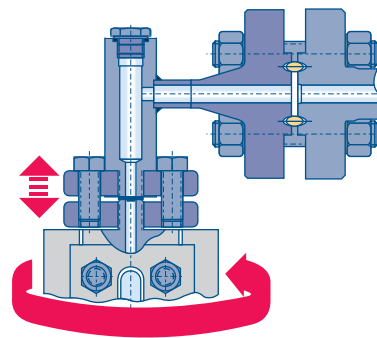
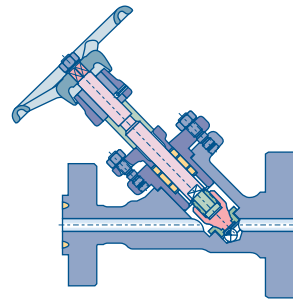

Male thread with two oval flanges and gasket, positive connection. When oval flanges are loosened the gauge body may be rotated through 360°.

Connection gauge body – shut-off fitting

Steam application

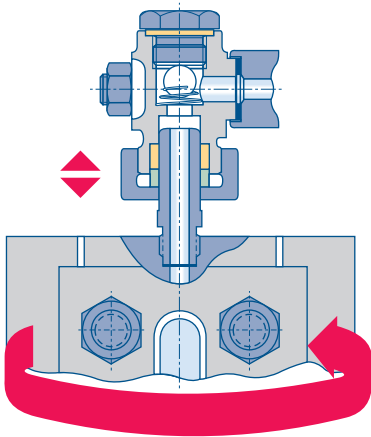

End-tubes contained in and sealed by gland ring. The connection is not positive, the gauge body may be easily rotated through 360°.

Process application

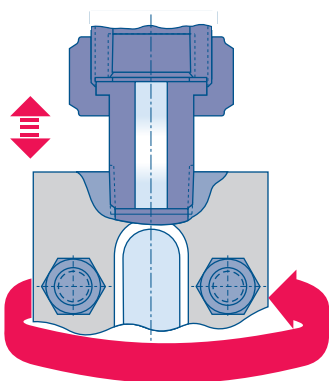

Single nipple with union nut and joint ring; positive connection; when union nut is loosened gauge may be rotated through 360°.

Double nipple; thread seals; positive connection; gauge body cannot be rotated

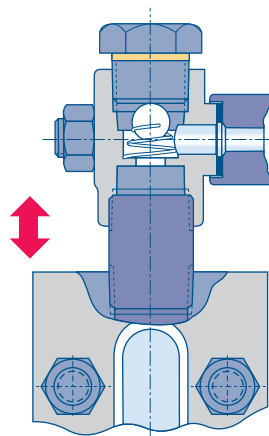



Shut-off fittings

Gauge cocks

D *Nominal pressure:*
PN 63, ANSI 400
Construction to KLINGER
ANSI 400 *material code FS/H, M/H*
Shut-off fitting for:
Gauges K, R 100-D

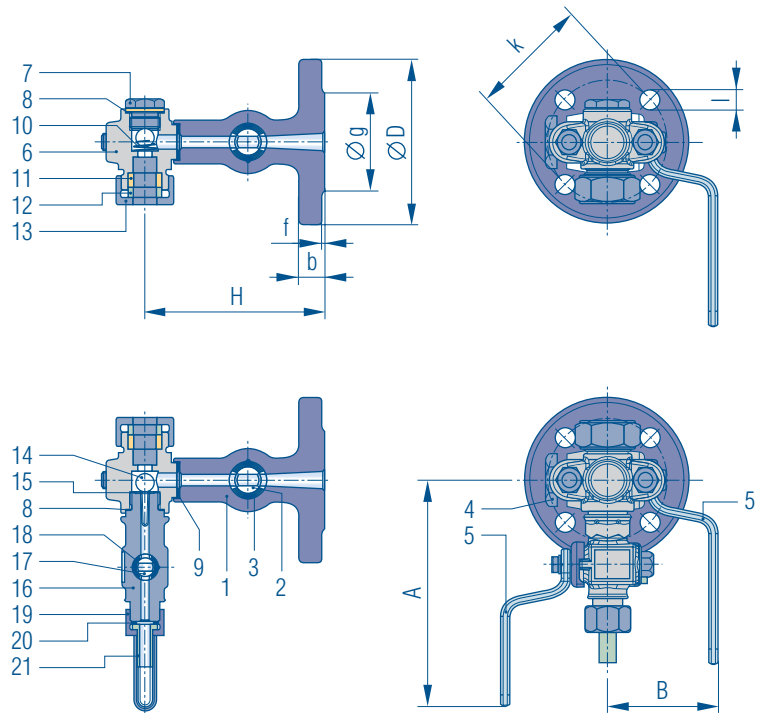

Overall and connection dimensions (mm)

Flange connexion	H	A	B	D	b	g	f	Drilled			Approx. kg
								No. of holes	l	k	
DN 20 PN 40	124	142	78	105	18	58	2	4	14	75	7,30
DN 25 PN 40	124	142	78	115	18	68	2	4	14	85	7,70
3/4" ANSI 300	123	142	78	117,5	16	43	1,6	4	19	82,6	7,70
1" ANSI 300	124	142	78	124	17,5	50,8	1,6	4	19	88,9	8,20

Connections

Vessel connections:

Standard flange dimensions, as shown in the table

Male screw connections with pipe thread to DIN 2999-R1/2" or R3/4"

Connection gauge body – gauge cock

The connection to the gauge is formed by K end-tubes (16 mm o.D.) which are rotatable held within the gauge cock stuffing box.

The gauge cocks are provided with safety balls in the upper and lower gauge cocks.

The lower gauge cock is provided with an ABL 12 drain cock.

Pos.	Part	Materials	
		FS/H	M/H
1	Gauge cock body	A105	F316L
2	Cock plug AB 18	AISI316	AISI316
3	Packing sleeve AB 18	Graphite	Graphite
4	Tightening nut	A105	AISI316
5	Handle	Fe37B-Nylon	Fe37B-Nylon
6	Stuffing-box body	A105 N	F316L
7	Plug	A105 N	AISI316
8	Gasket	Softnickel	Softnickel
9	Gasket	K-SIL	K-SIL
10	Pressure spring	AISI301	AISI301
11	Gland ring	Graphite	Graphite
12	Thrust ring	A105	A105
13	Union nut	A105	A105
14	Ball	AISI301	AISI301
15	Pressure spring	AISI301	AISI301
16	Drain cock body	A105	F316L
17	Plug AB 12	AISI316	AISI316
18	Packing sleeve Ab12	Graphite	Graphite
19	Union nut	A105	A105
20	Gasket	K-SIL	K-SIL
21	End tube	AISI316	AISI316

Shut-off fittings

Gauge cocks

Nominal pressure:
PN 160, ANSI 900
Construction to KLINGER
material code FS/H, M/H
Shut-off fitting for:
Gauges R 100, R 160, UOR,
T 50, T 100, UOT

DG
PN 160
ANSI 900
not rotatable

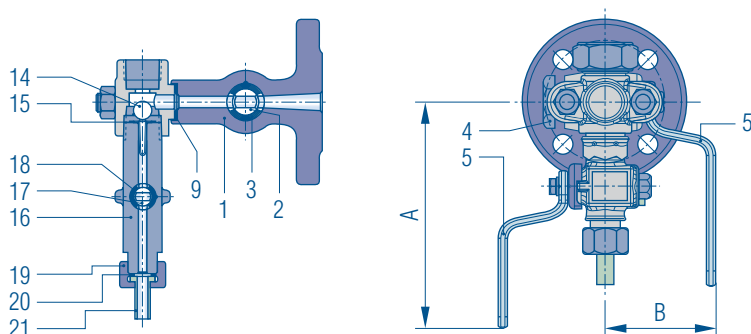
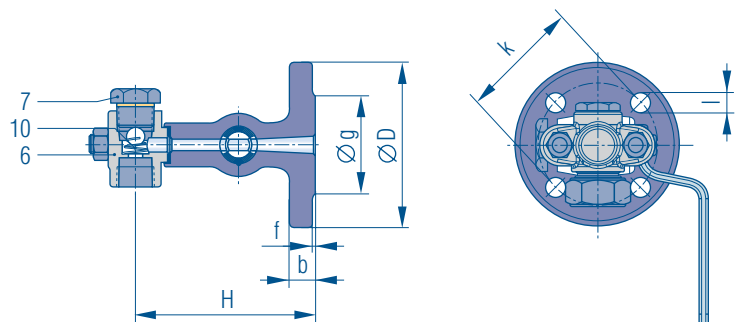

Overall and connection dimensions (mm)

Flange connexion	H	A	B	D	b	g	f	Drilled			Approx. kg
								No. of holes	l	k	
DN 20 PN 40	124	145	78	105	18	58	2	4	14	75	7,30
DN 25 PN 40	124	145	78	115	18	68	2	4	14	85	7,70
DN 25 PN 63/160	142	145	78	140	24	68	2	4	18	100	8,00
3/4" ANSI 300	123	145	78	117,5	16	43	1,6	4	19	82,6	7,70
1" ANSI 600	142	145	78	124	24	51	6,4	4	19	88,9	8,00
ANSI 900	on request										

Connections

Vessel connections:

Standard flange dimensions, as shown in the table. Male threaded connections to ANSI B 2.1 1/2"-14 NPT or 3/4"-14 NPT

Connection

gauge body – gauge cock

Gauge cock DG

1/2"-NPT double nipple

not rotatable

The upper and lower gauge cock is fitted with safety balls as standard.

The lower gauge cock is provided with an ABL 12-1/2"-NPT drain cock.

Pos.	Part	Materials	
		FS/H	M/H
1	Gauge cock body	A105	F316L
2	Cock plug AB 18	AISI316	AISI316
3	Packing sleeve AB 18	Graphite	Graphite
4	Tightening nut	A105	AISI316
5	Handle	Fe37B-Nylon	Fe37B-Nylon
6	Stuffing-box body	A105 N	F316L
7	Plug	A105 N	AISI316
9	Gasket	K-SIL	K-SIL
10	Pressure spring	AISI301	AISI301
14	Ball	AISI301	AISI301
15	Pressure spring	AISI301	AISI301
16	Drain cock body	A105	F316L
17	Plug AB 12	AISI316	AISI316
18	Packing sleeve AB 12	Graphite	Graphite
19	Union nut	A105	A105
20	Gasket	K-SIL	K-SIL
21	End tube	A105	A105



Shut-off fittings

Gauge cocks

DA *Nominal pressure: PN 160*
PN 160 *Construction to KLINGER*
material code FS/H
Shut-off fitting for:
Gauges T 85

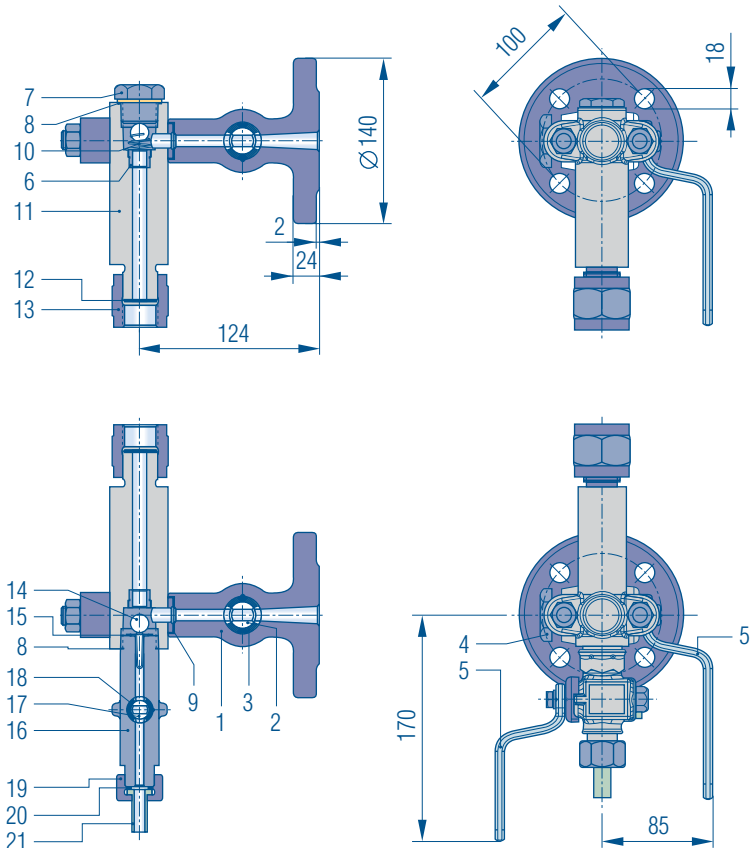

Pos.	Part	Materials
		FS/H
1	Gauge cock body	A 105
2	Cock plug AB 18	AISI 316
3	Packing sleeve AB 18	Graphite
4	Tightening nut	A 105
5	Handle	Fe37B-Nylon
6	Seat bush	1.4104
7	Plug	A 105 N
8	Gasket	Soft nickel
9	Gasket	K-SIL
10	Pressure spring	A 301
11	Connecting piece	C22.8
12	Gasket	Soft nickel
13	Tightening nut	9SMn28K
14	Ball	A 301
15	Pressure spring	A 301
16	Drain cock body	A 105
17	Plug AB 12	A 316
18	Packing sleeve AB 12	Graphite
19	Union nut	A 105
20	Gasket	K-SIL
21	End tube	A 105

Connection gauge body – gauge cock

The connection to the gauge is formed by conjunction with a connecting nut. The type ABL 12 drain cock is screwed into the lower connecting piece. The connecting pieces are fitted with safety balls as standard.

Set of DA connecting pieces, in conjunction with set of DA gauge cocks for gauge types T 85.

Shut-off fittings

Gauge valves

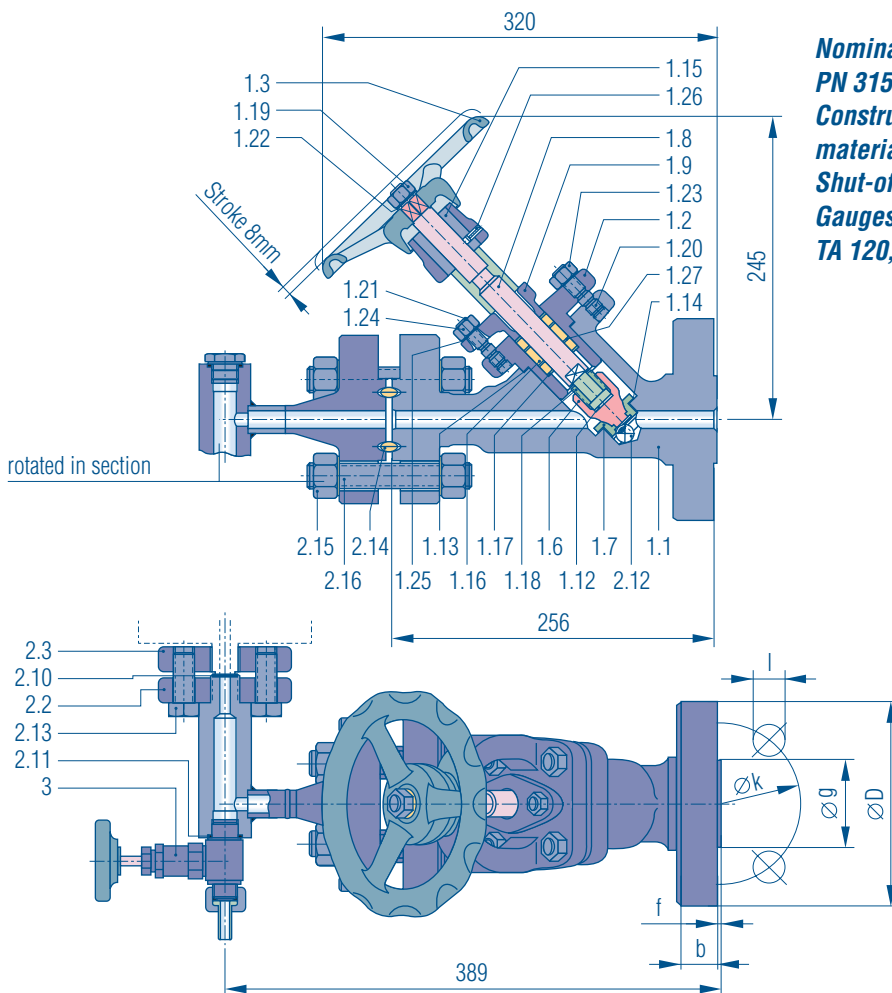

Nominal pressure:
PN 315, PN 250, PN 160
Construction to KLINGER
material code FS/H
Shut-off fittings for:
Gauges T 85,
TA 120, KTA

DVK 2
PN 315
PN 250
PN 160

Overall and connection dimensions (mm)

Flange connection	D	b	g	f	Drilled			Approx. kg
					No. of holes	l	k	
DN 25 PN 160	140	24	68	2	4	18	100	18
DN 25 PN 250	150	28	68	2	4	22	105	18
DN 25 PN 315	160	34	68	2	4	22	115	18

Pos.	Part	Material FS/H
1.1	Body	C22.8
1.2	Bonnet	C22.8
1.3	Handwheel	GG-20
1.6	Piston	4528 V
1.7	Seating ring	1.4571
1.8	Spindle	1.4104
1.9	Gland retainer	GGG-40
1.12	Shim washer	90MnV8
1.13	Gasket	Softnickel
1.14	Gasket	Softnickel
1.15	Threaded bush	Sint C11
1.16	Stuffing-box ring	Graphite
1.17	Bottoming ring	St 12.03 / FeCu 10 Ni 8p
1.18	Split nut	St 60 / FeCu 10 Ni 8p
1.19	Hexagon nut	5
1.20	Stud bolt	2CrMoV511

Pos.	Part	Material FS/H
1.21	Stud bolt	Ck35
1.22	Serrated lock washer	Spring steel
1.23	Hexagon nut	24CrMo5
1.24	Hexagon nut	C35
1.25	Belleville washer	50CrV4
1.26	Tension pin	Spring steel
2.1	Connecting piece	C22.8
2.2	Oval flange Ø17	St 42
2.3	Oval flange M16	St 42
2.8	Plug	9SMn28K
2.10	Gasket	Softnickel
2.11	Gasket	Softnickel
2.12	Ball	1.4034
2.13	Hexagon-headed screw	8.8
2.14	Gasket	Soft iron
2.15	Nut	C35
2.16	Stud bolt	Ck 35
3	Drain valve	

Connection gauge body – gauge cock

Connection to the gauge is made by connecting pieces with two flanges. The NV/ASP drain valve is screwed into the lower connecting piece. The gauge valves are fitted with safety balls as standard.



Shut-off fittings

Gauge valve

RAV 946

Nominal pressure:
PN 160, ANSI 900

RAV 947

Construction to KLINGER
material code FS/H, M/H

PN 160

Shut-off fitting for:

Gauges R25, R 100, R 160, R250
UOR, T 50, T 100, T 160, T 250, UOT

ANSI 900

not rotatable/rotatable

RAV 946 inside screw

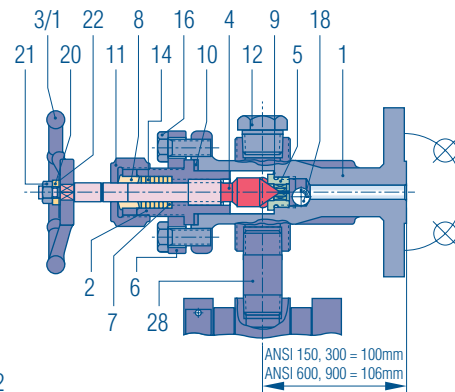

RAV 947 inside screw

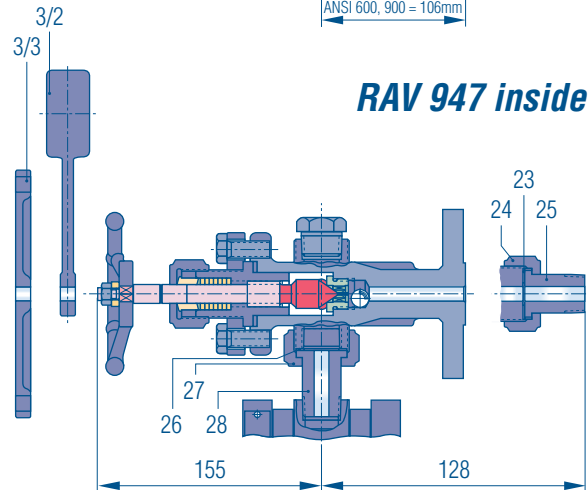

Connections

Standard flange dimensions, as shown in the table

Standard pattern with handwheel 13.1 normal shutting.

On request with weighted lever 13.2 quick shutting.

Gauge valves with spindle outside available on request.

Connection gauge body – gauge cock

RAV 946:

Double nipple (AD-nipple) 1/2"-NPT

RAV 947:

A-Nipple 1/2"-NPT

Gasket, union nut

The upper and lower gauge valves are fitted with safety balls as standard.

The lower gauge valve is provided with a 1/2"-NPT plug as standard.

Type ABL 12-1/2"-NPT drain cock can be supplied on request.

Pos.	Part	Materials	
		FS/H	M/H
1	Body	A 105 N	A 182 F 316L
2	Yoke sleeve	A 105	A 316
3/1	Handwheel	A 105	A 105
3/2	Weight lever	A 105	A 105
3/3	Double arm lever	A 105	A 105
4	Spindle	A 410	A 316
5	Seat	A 316L	A 316L
6	Loose flange	A 105 N	A 105 N
7	Washer	A 105 N	A 316
8	Packing gland	A 105 N	A 316L
9	Washer	Nickel	Nickel
10	Spiral wound gasket	Graphite/A 316	Graphite/A 316
11	Union nut	A 105	A 105
12	Plug 1/2"-14NPT	A 105	A 316
14	Packing 946	Graphite	Graphite
16	Hexagon headed screw	B7	B7
18	Ball	AISI 316	AISI 316
20	Washer	R 40	R 40
21	Hexagon nut	2H	2H
22	Identification plate	A 304	A 304
23	Gasket	K-Sil	K-Sil
24	Union nut	A 105	A 105
25	A-nipple 3/4"-14NPT	A 105	A 316L
26	Gasket 947	K-Sil	K-Sil
27	Union nut 947	A 105	A 105
28	A-nipple 1/2"-14NPT 947 or double-nipple 1/2"-14NPT 946	A 105	A 316L

Shut-off fittings

Gauge valve

RAV 956 outside screw

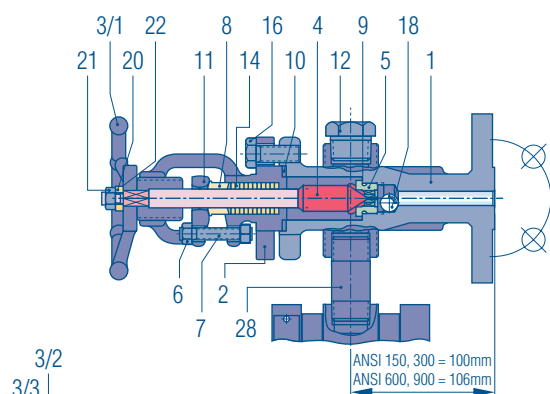

RAV 957 outside screw

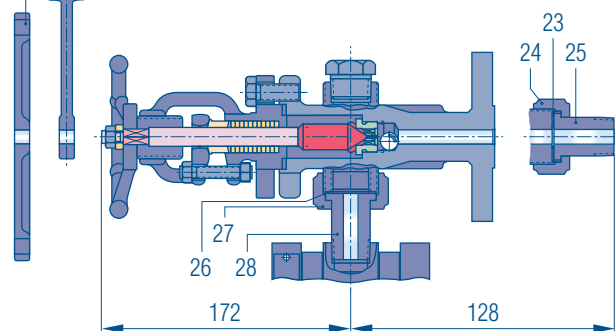

Nominal pressure:
PN 160, ANSI 900
Construction to KLINGER
material code FS/H, M/H
Shut-off fitting for:
Gauges R 25, R 100, R 160,
R 250, UOR, T 50, T 100,
T 160, T 250, UOT

RAV 956

RAV 957

PN 160

ANSI 900

not rotatable/rotatable

Connections

Standard flange dimensions, as shown in the table

Standard pattern with handwheel 13.1 normal shutting.

On request with weighted lever 13.2 quick shutting.

Gauge valves with spindle inside available on request.

Connection

gauge body – gauge cock

RAV 956:

Double nipple (AD-nipple) 1/2"-NPT

RAV 957:

A-Nipple 1/2"-NPT

Gasket, union nut

The upper and lower gauge valves are fitted with safety balls as standard.

The lower gauge valve is provided with a 1/2"-NPT plug as standard.

Type ABL 12-1/2"-NPT drain cock can be supplied on request.

Pos.	Part	Materials	
		FS/H	M/H
1	Body	A 105 N	A 182 F 316L
2	Yoke sleeve	A 105	A 316
3/1	Handwheel	A 105	A 105
3/2	Weight lever	A 105	A 105
3/3	Double arm lever	A 105	A 105
4	Spindle	A 410	A 316
5	Seat	A 316L	A 316L
6	Loose flange	A 105 N	A 105 N
7	Washer	A 105 N	A 316
8	Packing gland	A 105 N	A 316L
9	Washer	Nickel	Nickel
10	Spiral wound gasket	Graphite/A 316	Graphite/A 316
11	Union nut	A 105	A 105
12	Plug 1/2"-14NPT	A 105	A 316
14	Packing 946	Graphite	Graphite
16	Hexagon headed screw	B7	B7
18	Ball	AISI 316	AISI 316
20	Washer	R 40	R 40
21	Hexagon nut	2H	2H
22	Identification plate	A 304	A 304
23	Gasket	K-Sil	K-Sil
24	Union nut	A 105	A 105
25	A-nipple 3/4"-14NPT	A 105	A 316L
26	Gasket 947	K-Sil	K-Sil
27	Union nut 947	A 105	A 105
28	A-nipple 1/2"-14NPT 947 or double-nipple 1/2"-14NPT 946	A 105	A 316L



Liquid level gauges

Accessories

Illuminators *Illuminators for KLINGER bi-colour gauges*

Safety class IP 65

*EEx dII CT6, 230 V 50 Hz, 15 W
with red / green indication.
Lamp bulb with screwed base E 27.
Type approved according to ATEX.*

*Suitable for outdoor service.
Special voltage on request.*

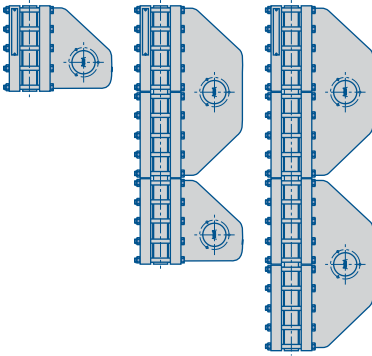

*With combined gauges a single illuminator is invariably used for two gauge sections (see illustration).
Suitable for use in outdoor service (especially in refineries).*

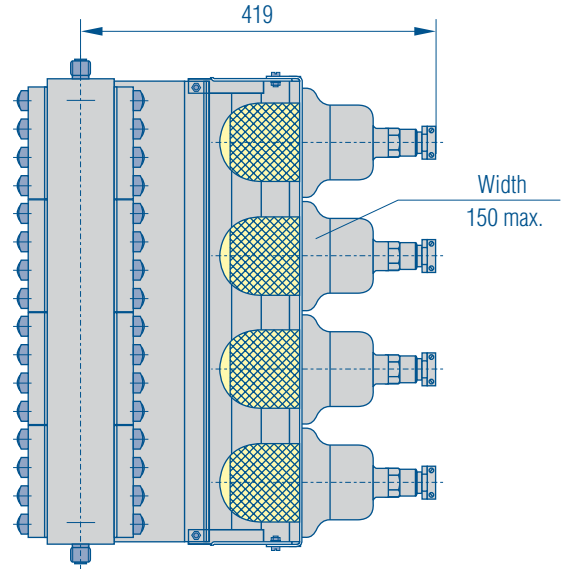

Explosion-proof illuminators for KLINGER transparent gauges

*As a general principle only explosion-proof illuminators are permitted in the process industry.
This applies also to steam boilers when located in process areas.*

Safety class IP 65

*Voltage 230 V, 50 Hz
Special voltage on request.
Suitable for use in outdoor services.*

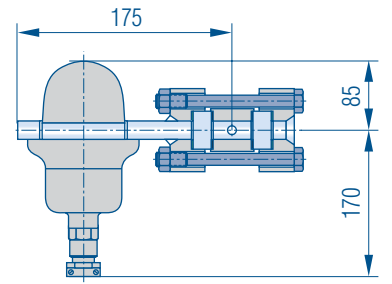

NV/ASP *Drain valve*

PN 400

**Nominal pressure PN 400
Construction to KLINGER
material code M/H**

Pos.	Part	Material
1	Body	1.4571
2	Valve cone	1.4122
3	Sealing ring	2.4055 (Ni)
4	Head piece	1.4571
5	Stuffing box	Graphite
6	Stuffing box nut	1.4401
7	Spindle	1.4404
8	Handwheel	Synthetic
9	Nut	1.4401
10	Screw coupling	A2
11	Sealing	K-Sil
12	Drain pipe	1.0402

*Size DN 8
Overall length: Klinger standard
Connection: R1/2"
Temperature: -40 °C to + 400 °C
Drain valve for gauge valve DVK-2*

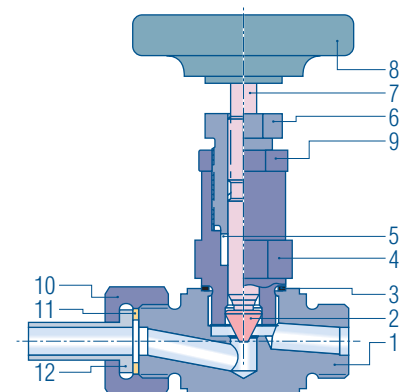

Liquid level gauges

Accessoires

For quick and simple operation of gauge cocks which cannot be reached by hand.

Double-arm lever for type D, DA, DG

Provided with fixtures for two operating cables (cables not supplied with levers).

Gauge cocks are operated independently.

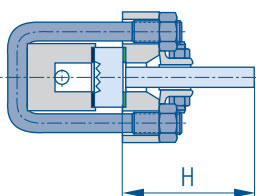
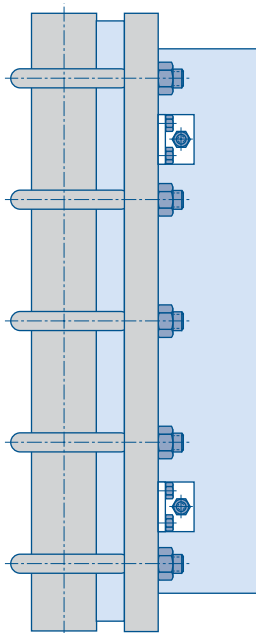
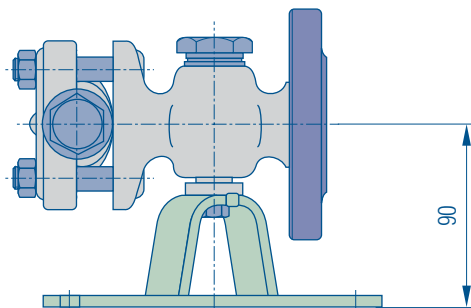
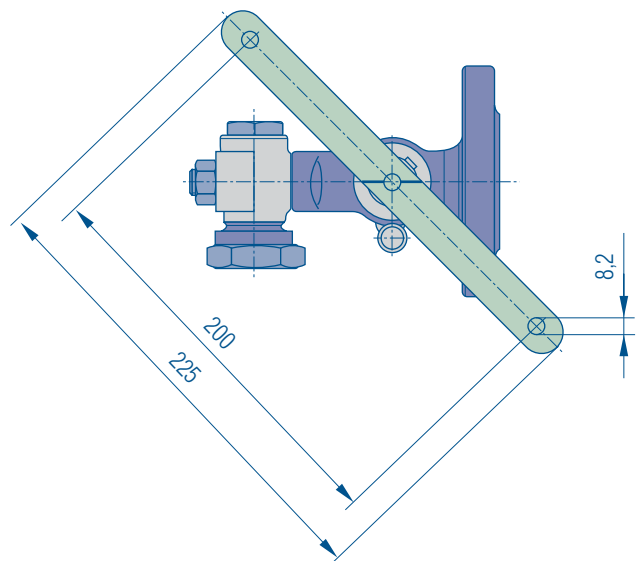

Non-frosting blocks

With cold media there is a danger of ice forming on the gauge glass from atmospheric moisture. The liquid can then no longer be observed through the gauge glass. Our non-frosting blocks (acrylic glass) keep the sight area free of ice and ensure unimpaired observation of the liquid level.

The width of the block is matched to the visible width of the glass; we select the thickness on the basis of the medium temperature.

With transparent gauges, non-frosting blocks must be provided on both gauge glasses.

H (mm) = at temperature up/down to			
-20 °C	-50 °C	-100 °C	below -100 °C
38	75	150	200



Liquid level gauges

Table of chemical Resistance

Table of Chemical Resistance

The recommendations given here are intended to help in selecting suitable materials. No guarantee can be given since the performance and service life of the products depend on a series of factors on which the manufacturer has no influence. If special regulations apply, these must be observed. Please contact us in cases of doubt. Where solid media are listed in the table, these are not to be understood as aqueous solutions or suspensions.

Abbreviations:

BP = boiling point

conc. = concentrate

satd. = saturated solution

x = suitable

- = not recommended

Footnotes to table of chemical resistance:

¹⁾ With heat-transfer media please inquire in our Gumpoldskirchen factory regarding choice of packing sleeves. Please state the type of medium and the temperature range.

Medium	Concentration and Temperature		Packing sleeves		Material code no.
	%	°C	KAF	KFG	
Acetic acid	10	20	x	x	M/H
Acetic acid	10	BP	x	x	M/H
Acetic acid	50	20	x	x	M/H
Acetic acid	50	BP	x	x	M/H
Acetic acid	80	20	x	x	M/H
Acetic acid	80	BP	x	x	M/H
Acetic acid		20	x	x	M/H
Acetone		20	x	x	all
Acetylene			-	x	FS/H, M/H
Air, dry			x	x	all
Alum	10	20	x	x	M/H
Alum	10	100	x	x	M/H
Aluminium acetate			x	x	M/H
Aluminium chlorate			x	x	M/H
Aluminium ethylate			x	x	all
Aluminium fluoride			x	x	FS/H
Aluminium oxide			x	x	all
Ammonia	10	20	x	x	FS/H, M/H
Ammonium carbonate		BP	x	x	M/H
Ammonium chloride	5	20	x	x	all
Ammonium chloride	10	20	x	x	all
Ammonium chloride	10	100	x	x	M/H
Ammonium chloride	50	20	x	x	M/H
Ammonium diphosphat (=Diammoniumphosphat)			x	x	FS/H, M/H
Ammonium hydroxide	10	100	x	x	FS/H, M/H
Ammonium nitrat		BP	x	x	M/H
Ammonium sulfat		BP	x	x	M/H
Amyl acetat			x	x	all
Aniline			x	x	all
Arsenic acid			x	x	M/H
Asphalt			x	x	M/H
Beer			x	x	M/H
Benzene			x	x	all
Bleaching solution (chloride of lime)	<10	60	x	x	M/H
Boric acid	4	20	x	x	M/H
Boric acid	4	100	x	x	M/H
Boric acid	100	100	x	x	M/H
Borax		satd.	x	x	M/H
Brine		20	x	x	M/H
Butane			x	x	all

Medium	Concentration and Temperature		Packing sleeves		Material code no.
	%	°C	KAF	KFG	
Butter milk		20	x	x	M/H
Butyl acetat			x	x	all
Butyl alcohol			x	x	all
Calcium bisulphite		20	-	x	M/H
Calcium bisulphite		200	-	x	M/H
Calcium chloride	satd.	20	x	x	M/H
Calcium chloride	satd.	100	x	x	M/H
Calcium hydroxide (slaked lime)			x	x	all
Calcium hypochlorite			-	x	M/H
Calcium sulphate			x	x	all
Carbon dioxide, dry		150	x	x	all
Carbon dioxide, dry		400	x	-	FS/H, M/H
Carbon disulphide		20	x	x	FS/H, M/H
Carbon tetrachloride			x	x	all
Chlorine, dry		20	x	-	all
Chlorine, dry		80	x	-	all
Chloroform		BP	x	x	all
Chlorosulphonic acid		20	x	-	all
Chromic acid	10	20	x	-	FS/H, M/H
Chromic acid	10	BP	-	-	M/H
Chromic acid	50	20	-	-	FS/H, M/H
Citric acid		20	x	x	M/H
Citric acid		BP	x	x	M/H
Coagulating baths (up to 10% H ₂ SO ₄)		80	x	x	M/H
Clophen T 64			x	x	all
Copper acetat		20	x	x	M/H
Copper acetat		BP	x	x	M/H
Copper sulphate (blue vitrol)		20	x	x	M/H
Copper sulphate (blue vitrol)		BP	x	x	M/H
Creosote		20	-	x	M/H
Creosote		BP	-	x	M/H
Cyanide of potassium		20	x	x	M/H
Diazotizing solutions, weakly acid		20	x	x	M/H
Diazotizing solutions, weakly acid		80	x	x	M/H
Diesel oil		80	x	x	all
Diphyl			x	-	all ¹⁾
Dowtherm A			x	-	all ¹⁾

Liquid level gauges

Table of chemical Resistance

Medium	Concentration and Temperature		Packing sleeves		Material code no.
	%	°C	KAF	KFG	
Dye bath, alkaline or neutral	20		x	x	M/H
Dye bath, alkaline or neutral	BP		x	x	M/H
Dye bath, organic acid	20		x	x	M/H
Dye bath, organic acid	BP		x	x	M/H
Dye bath, strong sulphuric acid	20		x	x	M/H
Dye bath, strong sulphuric acid	BP		x	x	M/H
Dye bath, weak sulphuric acid	BP		x	x	M/H
Ethane			x	x	all
Ethyl acetate	BP		x	x	all
Ethyl alcohol			x	x	all
Ethyl ether			-	x	all
Ethylene			-	x	all
Ethylene chloride	20		x	x	all
Fatty acids from C ₆ upwards			x	x	all
Formaldehyde	40	20	x	x	M/H
Formaldehyde	40	BP	x	x	M/H
Formic acid	10	20	x	x	M/H
Formic acid	10	100	x	x	M/H
Formic acid	100	20	x	x	M/H
Formic acid	100	100	x	x	M/H
Freon 12, Frigen 12			x	x	all
Glycerine	20		x	x	M/H
Glycerine	100		x	x	M/H
Heat transfer oils ¹⁾			x	-	all ¹⁾
Hydrochloric acid	0,2	20	x	x	M/H
Hydrochloric acid	0,2	50	x	x	M/H
Hydrochloric acid	1	20	x	x	M/H
Hydrogen			x	x	all
Hydrogen chloride, dry	20		x	x	all
Hydrogen chloride, dry	100		x	x	all
Hydrogen peroxide	20		x	x	M/H
Hydrogen peroxide	50		-	x	M/H
Hydrogen sulphide, gas, dry	20		x	x	M/H
Hydrogen sulphide, gas, moist	20		x	x	M/H
Hydroxylamine sulphate	10	20	x	x	M/H
Hydroxylamine sulphate	10	BP	x	x	M/H
Illuminating gas (town's gas)			x	x	all
Lead acetate	100	BP	x	x	M/H
Lead arsenate			x	x	M/H
Linsed oil	20		x	x	M/H
Linsed oil	BP		x	x	M/H
Magnesium sulphate	20		x	x	all
Magnesium sulphate	BP		x	x	all
Manganous chloride	20		x	x	M/H
Manganous chloride	BP		x	x	M/H
Mercury	20		x	x	FS/H, M/H
Mercuric (II) chloride	20		x	x	M/H
Mercuric (II) nitrate	20		x	x	M/H

Medium	Concentration and Temperature		Packing sleeves		Material code no.	
	%	°C	KAF	KFG		
Methyl alcohol	20		x	x	all	
Methyl alcohol	BP		x	x	all	
Methylene chloride	20		x	x	M/H	
Methylene chloride	BP		x	x	M/H	
Methyl ethyl ketone (MEK, butanone)	BP		x	x	all	
Milk			x	x	M/H	
Natural gas			x	x	all	
Nitric acid	10	20	x	x	M/H	
Nitric acid	10	BP	x	x	M/H	
Nitric acid	40	20	x	x	M/H	
Nitric acid	40	BP	x	x	M/H	
Nitric acid	conc.	20	-	x	M/H	
Nitric acid	conc.	BP	-	x	M/H	
Nitrogen			x	x	all	
Oils (lubricating, mineral)	20		x	x	all	
Oils (vegetable)	20		x	x	all	
Oleic acid			-	x	all	
Oxalic acid			x	x	M/H	
Oxygen	20		x	x	all	
Paraffin oil (kerosine)	20		x	x	all	
Petrol (gasoline)			x	x	all	
Phenol (carbolic acid)			x	x	M/H	
Phosphoric acid	10	20	x	x	M/H	
Phosphoric acid	10	BP	x	x	M/H	
Phosphoric acid	50	20	x	x	M/H	
Phosphoric acid	50	BP	x	x	M/H	
Phosphoric acid	80	20	x	x	M/H	
Phosphoric acid	80	BP	x	x	M/H	
Potassium acetat			BP	x	all	
Potassium bitartrate	20		x	x	M/H	
Potassium bitartrate	satd.	BP	x	x	M/H	
Potassium carbonate (potash)	50	20	x	x	all	
Potassium carbonate (potash)			BP	x	all	
Potassium chlorate			BP	-	x	M/H
Potassium chromium sulphate (chrome alum)	20		x	x	M/H	
Potassium chromium sulphate (chrome alum)	BP		x	x	M/H	
Potassium cyanide	20		x	x	FS/H, M/H	
Potassium dichromate	25	20	x	x	all	
Potassium dichromate			BP	-	x	M/H
Potassium hydroxide (caustic potash)	25	20	x	x	all	
Potassium hydroxide (caustic potash)	25	BP	x	x	M/H	
Potassium hydroxide (caustic potash)	50	20	x	x	all	
Potassium hydroxide (caustic potash)	50	BP	x	x	M/H	
Potassium hypochlorite (up to 20 mg active chlorine/litre)	40		x	x	M/H	



Liquid level gauges

Table of chemical Resistance

Medium	Concentration and Temperature		Packing sleeves		Material code no.
	%	°C	KAF	KFG	
Potassium iodide	20		x	x	FS/H, M/H
Potassium iodide	BP		x	x	M/H
Potassium nitrate	20		-	x	all
Potassium nitrate	satd.	BP	-	x	M/H
Potassium permanganate	20		x	x	all
Potassium permanganate	BP		-	x	M/H
Propane	20		x	x	all
Salicylic acid	20		x	x	M/H
Sea water	20		x	x	M/H
Sea water	BP		x	x	M/H
Silicone oils			x	-	all
Slaked lime	20		x	x	all
Slaked lime	BP		x	-	all
Soap solution			x	x	all
Soda (sodium carbonate) cold	BP		x	x	all
Sodium acetate			x	x	all
Sodium carbonate (soda solution)	satd.	20	x	x	all
Sodium carbonate (soda solution)		BP	x	x	all
Sodium hydroxide (caustic soda)	20	20	x	x	all
Sodium hydroxide (caustic soda)	20	BP	x	x	M/H
Sodium hydroxide (caustic soda)	35	20	x	x	all
Sodium hydroxide (caustic soda)	35	BP	x	x	M/H
Sodium sulphate			x	x	all
Starch			x	x	M/H

Medium	Concentration and Temperature		Packing sleeves		Material code no.
	%	°C	KAF	KFG	
Steam			x	-	all
Stearic acid			x	-	M/H
Sugar		20	x	x	all
Sugar		80	x	x	all
Sulphite solutions (fresh boiled or waste)		20	x	x	M/H
Sulphite solutions (fresh boiled or waste)		80	x	x	M/H
Sulphur dioxide			x	x	M/H
Sulphuric acid	1	20	x	x	M/H
Sulphuric acid	10	20	x	x	M/H
Sulphuric acid	90	20	x	x	FS/H, M/H
Sulphuric acid	conc.	20	x	x	all
Sulphurous acid	satd.	20	x	x	M/H
Tannic acid	10	20	x	x	M/H
Tannic acid	10	BP	x	x	M/H
Tannic acid	50	20	x	x	M/H
Tar (neutral)		180	x	x	FS/H, M/H
Tartaric acid		20	x	x	M/H
Toluene		20	x	x	all
Trichlorethylene			x	x	all
Turpentine		20	x	x	all
Urea		20	x	x	all
Water (sweet and drinking)			x	x	all
Waterglass (potassium / sodium silicate)			x	x	all
Wine vinegar		20	x	x	M/H
Xylene		20	x	x	all

Liquid level gauges

Pressure-Temperature-Table, Pressure rating

Pressure-Temperature-Table for saturated steam

Pressure bar	Saturated steam °C	Pressure bar	Saturated steam °C
0,01	6,6	8,5	172,1
0,015	12,7	9,0	174,5
0,02	17,1	9,5	176,8
0,025	20,7	10	179,0
0,03	23,7	11	183,2
0,04	28,6	12	187,1
0,05	32,5	13	190,7
0,06	35,8	14	194,1
0,08	41,1	15	197,4
0,10	45,4	16	200,4
0,12	49,0	17	203,4
0,15	53,6	18	206,2
0,20	59,7	19	208,8
0,25	64,6	20	211,4
0,30	68,7	22	216,2
0,35	72,3	24	220,8
0,40	75,4	26	225,0
0,50	80,9	28	229,0
0,60	85,5	30	232,8
0,70	89,5	32	236,4
0,80	93,0	34	239,8
0,90	96,2	36	243,1
1,0	99,1	38	246,2
1,1	101,8	40	249,2
1,2	104,2	42	252,1
1,3	106,6	44	254,9
1,4	108,7	46	257,6
1,5	110,8	48	260,2
1,6	112,7	50	262,7
1,8	116,3	55	268,7
2,0	119,6	60	274,3
2,2	122,6	65	279,6
2,4	125,5	70	284,5
2,6	128,1	75	289,2
2,8	130,5	80	293,6
3,0	132,9	85	297,9
3,2	135,1	90	301,9
3,4	137,2	95	305,8
3,6	139,2	100	309,5
3,8	141,1	110	316,5
4,0	142,9	120	323,1
4,5	147,2	130	329,3
5,0	151,1	140	335,0
5,5	154,7	150	340,5
6,0	158,1	160	345,7
6,5	161,2	180	355,4
7,0	164,2	200	364,2
7,5	167,0	224	372,0
8,0	169,6	225	374,0

Pressure rating

Pressure rating	Material of pipe-line parts					Permissible working pressure in pipe-line in bar for temperature °C									
	Flanges valves				Bolt to DIN 2507 sheet 2 ¹⁰⁾										
	Cast iron with laminar graphite ¹¹⁾	Cast iron with spheroidal graphite ¹¹⁾	Cast steel	Steel		³⁾ 20 (120)	200	250	300	350	400				
6	GG-20	GGG-38	-	St 37-2	4 D	6*)	-	-	-	-	-	-	-	-	-
						6	5	4,5*)	3,6*)						
10	GG-20	GGG-38	GS-45	St 37-2	4 D	10 ⁴⁾	-	-	-	-	-	-	-	-	-
						10	8	7*)	6*)						
16	GG-20	GGG-38	GS-45	St 37-2	4 D	16 ⁴⁾	-	-	-	-	-	-	-	-	-
						16	13	11*)	10*)						
	-	-	1.0619	C 22N	C 35	16	14	13	11	10	8				
25	-	GGG-38	GS-45.5	C 22 N	4 D ²⁾	25 ⁴⁾	-	-	-	-	-	-	-	-	-
						25	20	18	16						
	-	-	1.0619	C 35	C 35	25	22	20	17	16	13				
			GS-22 Mo 4	15 Mo 3	24 CrMo 5			25	22	20	19				
			GS-17 CrMo 55	13 CrMo 44	24 CrMoV 55				25	24	23				
40	-	-	GS-45.5	C 22 N	4 D ²⁾	40	32	28	24						
						40	-	-	-						
	-	-	1.0619	C 35	C 35	40	35	32	28	24	21				
			GS-22 Mo 4	15 Mo 3	24 CrMo 5			40	35	31	30				
			GS-17 CrMo 55	13 CrMo 44	24 CrMoV 55				40	38	36				
63	-	-	1.0619	C 22 N	C 35	63	36	29	24						
						63	50	45	40						
	-	-	-	-	-	63	-	-	-						
						63	50	45	40	36	32				
			GS-22 Mo 4	15 Mo 3	24 CrMo 5			63	56	50	47				
			GS-17 CrMo 55	13 CrMo 44	24 CrMoV 55				63	61	58				
100	-	-	1.0619	C 22 N	C 35	100	80	70	60						
						100	-	-	-						
	-	-	-	-	-	100	80	70	60	56	50				
			GS-22 Mo 4	15 Mo 3	24 CrMo 5			100	87	78	74				
			GS-17 CrMo 55	13 CrMo 44	24 CrMoV 55				100	95	91				
160	-	-	1.0619	C 22 N	C 45	160	130	112	96						
						160	-	-	-						
	-	-	-	-	-	160	130	112	96	90	80				
250	-	-	1.0619	C 22 N	C 45	250	200	175	150						
						250	-	-	-						
	-	-	-	-	-	250	200	175	150	140	125				
315	-	-	1.0619	C 22 N	C 45	315	250	225	192						
						315	-	-	-						
	-	-	-	-	-	315	250	225	192	180	160				
400	-	-	1.0619	C 22 N	C 45	400	320	280	240						
						400	-	-	-						
	-	-	-	-	-	400	320	280	240	225	200				

³⁾ The permissible working pressure at 20°C may be applied in the case of ferrous materials in the temperature range from -10 to 120°C.

⁴⁾ Stress limitations: up to 120°C: for liquids provided the product of the inside diameter in mm and the working pressure in N/m² does not exceed the following values: 72.000 for St 00 and St 33, 100.000 for St 37, for compressed air and non hazardous gases to 100 N/cm². Up to 180°C: for saturated steam up to 100 N/cm²; for gas pipe-lines see also DIN 2470, DIN 2460 and DIN 2461.

¹⁰⁾ The strength value of the bolts is listed with a temperature 15°C lower than the working temperature.

¹¹⁾ With cast iron gate valve the permissible working pressures shown in the dimensional standards (e.g. DIN 3201) apply.

¹²⁾ Only with soft gaskets; bolts C35 metal gaskets or composite metal/soft gaskets.

^{*)} Permissible working pressure for valves is same as at 200°C if GG-20 ans 5 D bolts are used.



KLINGER product range

Product range

Ballostar®KHA

3piece ball valve made of grey cast iron, steel and stainless cast steel

Ballostar®KHI

2piece ball valve made of grey cast iron, steel and stainless cast steel

KLINGER Monoball®

One-piece ball valve made of steel and stainless cast steel

KLINGER Ball-o-top

Brass ball valves

Piston valves KVN

made of grey cast iron, nodular cast iron, steel and stainless cast steel

KLINGERMATIC®

Actuator for piston valves and ball valves

Liquid level gauges

for steam boiler and process application

Reflex and transparent sight-glasses

Circular sight-glasses

AB cocks

Packing-sleeve cocks and pressure-gauge cocks in brass, steel and stainless steel

Key role

Link

Innovation

Navigation

Growth

Efficiency

Routine